

# User manual PICAS



**PEEKEL  
INSTRUMENTS**

PEEKEL INSTRUMENTS B.V  
INDUSTRIEWEG 161  
3044 AS ROTTERDAM  
TEL: (010)-415 27 22  
FAX: (010)-437 68 26  
EMAIL: [sales@peekel.nl](mailto:sales@peekel.nl)

PEEKEL INSTRUMENTS GMBH  
BERGMANNSTRASSE 43  
44809 BOCHUM  
TEL: 0234/904 1603  
FAX: 0234/904 1605  
EMAIL: [Peekel@t-online.de](mailto:Peekel@t-online.de)

# Contents:

- 1. Introduction.....4**
  - 1.1 Power.....4
  - 1.2 General.....5
  - 1.3 The Carrier Frequency principle.....5
  - 1.4 General design principles.....6
  
- 2 Connecting the instrument.....7**
  - 2.1 Carrier frequency inputs on CA2CF.....7
    - 2.1.1 Connecting the Transducers.....7
    - 2.1.2 About Cable-capacitance.....7
    - 2.1.3 Bridgeconnector pinout.....8
    - 2.1.4 Full-bridge.....9
    - 2.1.5 Half-bridge.....10
    - 2.1.6 Quarter-bridge using 2-wires.....11
    - 2.1.7 Quarter-bridge using 3-wires.....11
    - 2.1.8 Displacement Transducers.....12
    - 2.1.9 Potentiometer connection.....13
  - 2.2 Analog inputs on CA4AI.....14
    - 2.2.1 Analog input connector pinout.....15
    - 2.2.2 Potentiometer connection.....16
    - 2.2.3 Connection of a resistor sensor like a PT100.....16
    - 2.2.4 Connection of a voltage signal.....17
    - 2.2.5 Connection of a 4 – 20 mA Sensor.....17
    - 2.2.6 Connection of a 0-20mA Sensor.....18
    - 2.2.7 Connection of a Thermocouple element.....18
  - 2.3 Outputs.....19
    - 2.3.1 Combined analog output.....19
    - 2.3.2 Digital Outputs.....19
    - 2.3.3 Digital Inputs.....19
  - 2.4 Communication ports.....20
    - 2.4.1 RS232 interface.....20
    - 2.4.2 USB.....20
    - 2.4.3 RS485 interface.....21
    - 2.4.4 Rear panel connections.....22
    - 2.4.5 Option Sum & difference values.....23
  
- 3 Setting-up the instrument.....24**
  - 3.1 General.....24
    - 3.1.1 Power up.....24
    - 3.1.2 Presentation of numbers.....24
    - 3.1.3 Conventions.....24
    - 3.1.4 Settings Protection.....25
  - 3.2 Software Installation.....25
    - 3.2.1 Loading new versions of firmware (Updates).....25
  - 3.3 Human Interfacing.....25
    - 3.3.1 Navigating the LCD display and the pushbuttons.....25
    - 3.3.2 Fields.....27
  - 3.4 Measuring Display.....29
    - 3.4.1 Actual value display.....29
    - 3.4.2 Peak value display.....30
    - 3.4.3 Sum – difference value display.....31
    - 3.4.4 Bar graph value display.....31
  - 3.5 System-menu's.....32
    - 3.5.1 System-menu: GENERAL.....34
    - 3.5.2 System-menu: Communication.....35
    - 3.5.3 System-menu: Actions.....36
    - 3.5.4 System-menu: Memory.....37

3.5.5 System-menu: Measuring Parameters .....38

3.5.6 System-menu: Datalog .....39

3.5.7 System-menu: Password.....41

3.6 CA2CF channel menu's.....42

3.6.1 CA2CF -menu: GENERAL.....43

3.6.2 CA2CF -menu: SENSOR.....45

3.6.3 CA2CF -menu: STRAIN.....46

3.6.4 CA2CF -menu: RANGE .....47

3.6.5 CA2CF -menu: BALANCE .....48

3.6.6 CA2CF -menu: TRIPS .....49

3.7 CA4AI channel menu's .....50

3.7.1 CA4AI menu: GENERAL .....51

3.7.2 CA4AI menu: Sensor .....52

3.7.3 CA4AI menu: Range .....53

3.7.4 CA4AI menu: Tara .....54

3.7.5 CA4AI menu: Trips .....55

**4 Problem resolving .....57**

**5 Technical Specifications.....58**

Version number	2.7.0
Release date	March 2008
Author	J.H. Steeneveld

# 1. Introduction

## 1.1 Power

The instrument is powered from an earthed 230 V / 50 Hz mains through a standard euro-plug.

The power switch is at the rear.

**WARNING**

Do not open the case. There are no user serviceable parts inside.

Danger for electrical shock hazard!!

Just below the power switch the fuse of 1A slow is present.

**WARNING**

Replacing the fuse must be done with the power cord disconnected, to prevent electrical shock hazard

## 1.2 General

PICAS is a tabletop stand-alone compact amplifier system from Peekel Instruments B.V. It can be connected as one node (station) in a larger, decentralized system by using the integrated RS-485 bus connection.

PICAS is delivered with an LCD-front and pushbuttons for the operation of the system. The PICAS can be also be connected to a external PC through a RS232 or USB interface.

It is designed to be used for high-accuracy experimental and industrial measurements and can be used with a variety of Wheatstone bridge-based sensors.

PICAS can hold 2 input cards. These input cards can be the CA2CF or CA4AI cards.

The CA2CF card comprises 2 high-accurate galvanic isolated carrier frequency amplifier channels each with its own analog output. On these channels a variety of resistive strain gauge configurations can be connected for experimental materials testing. Also Load cells can be connected for industrial weighing and force measurements. LVDT's (Linear Variable Differential Transformers) can be used for measuring linear or angular displacements and also Capacitive Transducers can be connected.

The CA4AI card comprises 4 input channels for voltage, current or resistor measurements. PICAS contains a control board which comprises a microprocessor which controls the amplifier settings, keyboard and display handling and the communication to external systems through the serial communication channels.

## 1.3 The Carrier Frequency principle

High-accuracy measuring at the output of passive transducers is usually configured into some sort of a Wheatstone Bridge circuit which always needs some form of reference (bridge supply) voltage.

DC bridge supply is by far the most popular for resistive transducers, but when it comes to the highest sensitivity, DC might introduce different spurious voltages which makes the measuring unreliable. In the late 50's PEEKEL already developed the Carrier Frequency principle for these applications, where an AC voltage is being used for the supply, which eliminates most of these spurious and misleading signals. Furthermore, AC bridge supply can be also used together with capacitive and inductive transducers.

If dynamic signals are being measured, the AC bridge supply voltage will be "modulated" by the measuring signal and by "detecting" this signal, the output signal becomes available. This way of measuring, through modulation of a carrier frequency with detection in a later step, is similar to the principle of AM radio. Hence, the term "Carrier Frequency" is being used.

The inherent use of isolation transformers assures a complete isolation between the sensing circuit and the rest of the system.

### 1.4 General design principles

The following drawings only show the basic principles of the carrier frequency amplifier, as it is outside the scope of this user’s manual to go in full detail.

Basically, PICAS houses 1 controller board which controls the settings of the amplifiers as well as the communication with external devices like a PC.

Also PICAS can hold up to 2 input cards, of the type CA2CF or CA4AI or a mix of those cards.

#### The carrier frequency Amplifiers

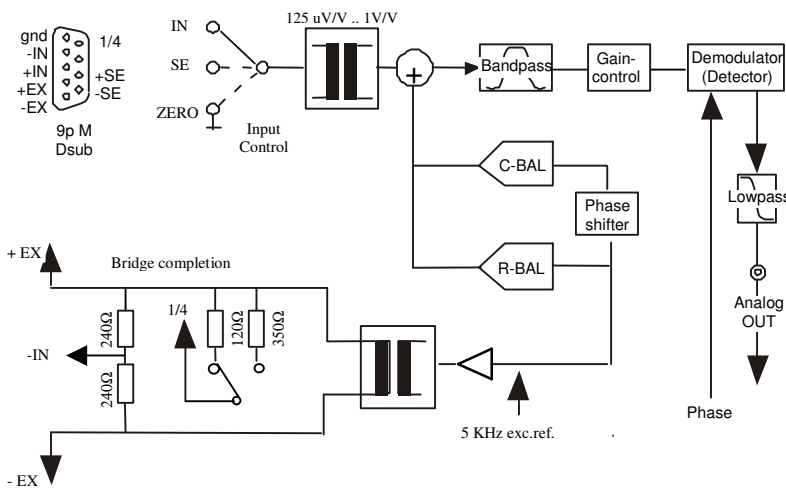

The drawing shows the evident advantage: the two transformers, fully isolating the measuring input from the rest of the system.

#### The Controller board

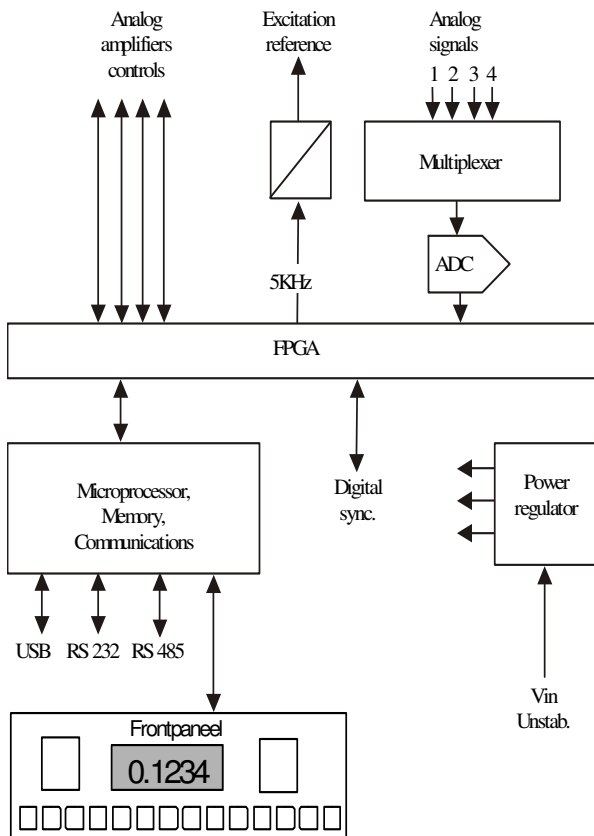

The blockdiagram shows the basic elements of the central processor module.

#### Further hardware components.

Apart from the basic module, the PICAS cabinet further houses the power supply, the LCD display-module, the front with integrated pushbuttons and a backpanel with various input- and output- connectors.

## 2 Connecting the instrument

### 2.1 Carrier frequency inputs on CA2CF

The following pages show examples of the various options of how to **connect** various input signals and transducers to the instrument. Later in this document, further details are given of how to actually **measure** these signals.

#### 2.1.1 Connecting the Transducers

The carrier-frequency amplifier is mainly used for strain gauges and IVDT's. They are connected in full-, half- or quarter-Wheatstone bridge configurations, having 4, 2 or 1 external strain gauges, resistors, inductances or capacities respectively. The other arms of the bridge can be completed with the internal, on-board, 1/2- and 1/4-bridge complementary-resistors. (As a standard, these are 240  $\Omega$  for 1/2 bridge and 120  $\Omega$  for 1/4 bridge.)

The precise value for a half-bridge completion is not important as long as these resistors are stable and in balance. The value of a quarter-bridge completion resistor, however, should fairly accurately match the external strain gauge, otherwise a too large unbalance (offset) will be the result.

All drawings show dotted lines, connecting the  $\pm SE$  with the  $\pm EX$  lines. These are the **sense-lines** and **must be connected**, even when not 6 but only 4 wires to the strain gauge-bridge are used.

The drawings include polarity-signs within the strain gauge-resistors. These indicate the polarity of the amplifier-output-signal for increasing strain and increasing resistance. It is strongly recommended to use shielded cables.

#### 2.1.2 About Cable-capacitance

A topic, inherent with the use of CF-amplifiers (contrary to DC-amplifiers) is cable-capacitance. The capacitance between cables to a strain gauge-bridge yields a parasitic impedance, parallel to the arms of the Wheatstone bridge. Any unbalance in capacitance may therefore lead to errors in the measured signal.

This becomes crucial in quarter-bridge configurations, where the capacitance comes directly across one arm of the bridge.

(Example: every 1 meter cabling of 100 pF/meter, connecting a 120  $\Omega$  bridge to a 5 kHz carrier-frequency amplifier, gives rise to 100  $\mu V/V$  C-signal offset. The carrier-frequency-amplifier luckily does suppress this C-signal by at least a factor 1000. However, this works only if the amplifier is not overloaded by the C-signal. The C-signal therefore should not be more than 4...7 times the selected measurement-range of the amplifier. In the most-sensitive range of 100  $\mu V/V$  this would allow for 10 meters of cabling.)

The presence of such a large C-signal is not recommended though. In quarter-bridge configurations therefore, it is common practice to compensate the capacitance by a fixed capacitor, built in the other arm (between pins  $+EX$  and  $1/4$ ).

### 2.1.3 Bridgeconnector pinout

pin 1	:	-EX	(-excitation)
pin 2	:	+EX	(+excitation)
pin 3	:	+IN	(+input)
pin 4	:	-IN	(-input)
pin 5	:	Gnd	(ground)
pin 6	:	-SE	(-sense)
pin 7	:	+SE	(+sense)
pin 8	:		
pin 9	:	1/4	(quarter-bridge completion resistor, 120 or 350 ohm)

The strain-gauge-bridges and lvdt's are connected through 9-pole male DSUB connectors. The pin connections are shown in the above table. The abbreviations are as follows:

**±EX** Excitation to the transducers. For the carrier-frequency-amplifier this is an ac-signal of 0,5 to 5 volt at normally 5000 Hz. Although the polarity-signs do not have a meaning for this ac-signal, they are used here to indicate the relation with +IN and -IN.

**±IN** Differential input of the amplifier. Like for the excitation, the polarity-signs wouldn't have a meaning if they weren't used to indicate the relation with +EX and -EX. Connecting +EX to +IN and -EX to -IN should give a positive (but overload) output signal.

**±SE** Sense-lines for 6-wire connection of full-bridges. The + SE and - SE connections have to be connected (see diagrams at the next pages) in order to compensate for the voltage drop of the EXcitation voltage over the lines, connected to the measuring sensors.

**1/4** Quarter-bridge completion resistor. (120Ω or 350Ω precision-resistor.). A single external strain-gauge can be completed by the internal resistors in the other bridge-arms, available through 1/4-pin. The 1/4-bridge completion resistor is internally connected to +EX. With the settings a choice can be made between a 120 Ω or a 350 Ω internal compensation resistor.

**Gnd** -ground. At this pin the ground from the system is connected. Normally this pin is not used

**Screen** When a cable is used with a screen, this screen must be connected to the housing of the connector. For the optimal screening this housing must be metalised.

### 2.1.4 Full-bridge

Figure 1 shows the connection of a full strain-gauge-bridge. This is the most reliable configuration. The leadwire-resistances affect only the sensitivity of the bridge. For instance  $6\Omega$  resistances in both the +EX as well as the -EX wire, connected to a  $120\Omega$  bridge, give a decrease in output signal of 9.1%. This can be compensated by using the internal sense circuit. However, that does not compensate the temperature-influence on the leadwire-resistance. A temperature-coefficient of  $0.4\%/^{\circ}\text{C}$  on  $12\Omega$  of copper wire, connected to a  $120\Omega$  bridge, will still give  $0.04\%/^{\circ}\text{C}$  change in sensitivity. Short, thick cabling is therefore recommended.

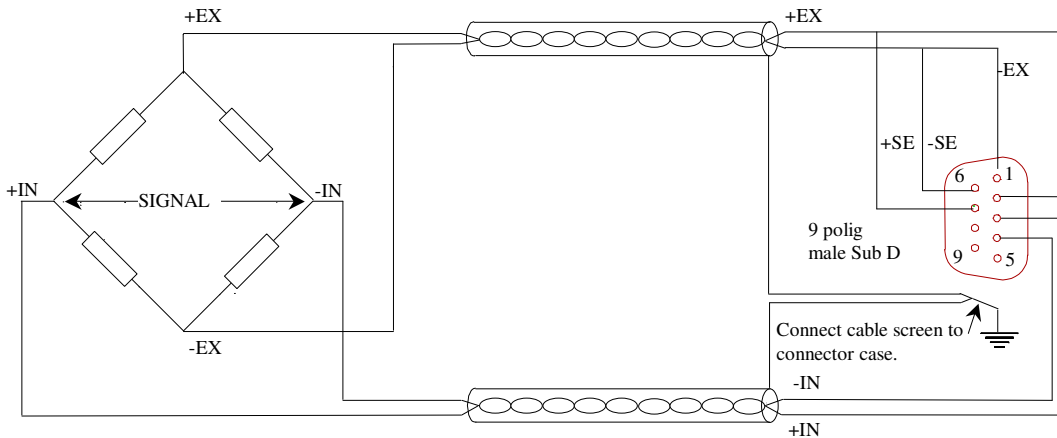

**Figure 1:** Full-bridge, 4-wire, strain-gauge-connection

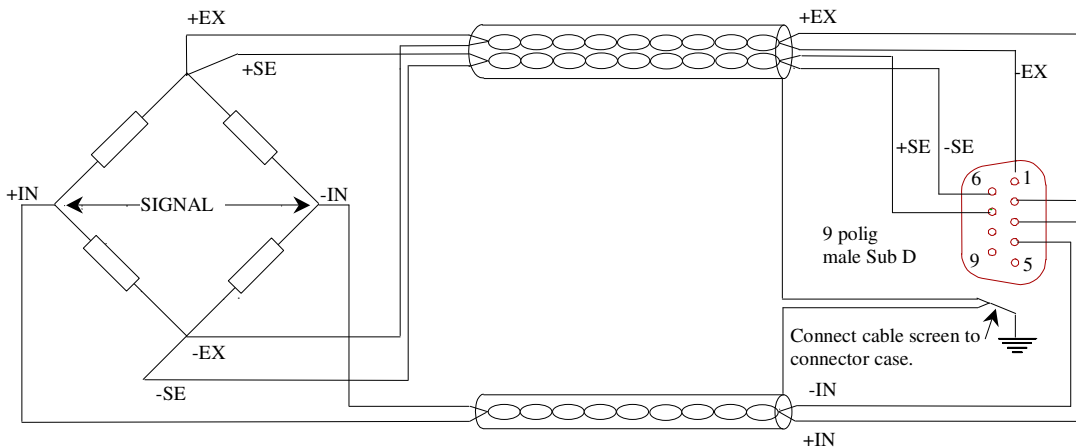

**Figure 2:** Full-bridge, 6-wire, strain-gauge-connection

### 2.1.5 Half-bridge

Figure 2 shows half-bridge configured straingauges. The 1/2-bridge completion-resistors are internally connected to -IN.

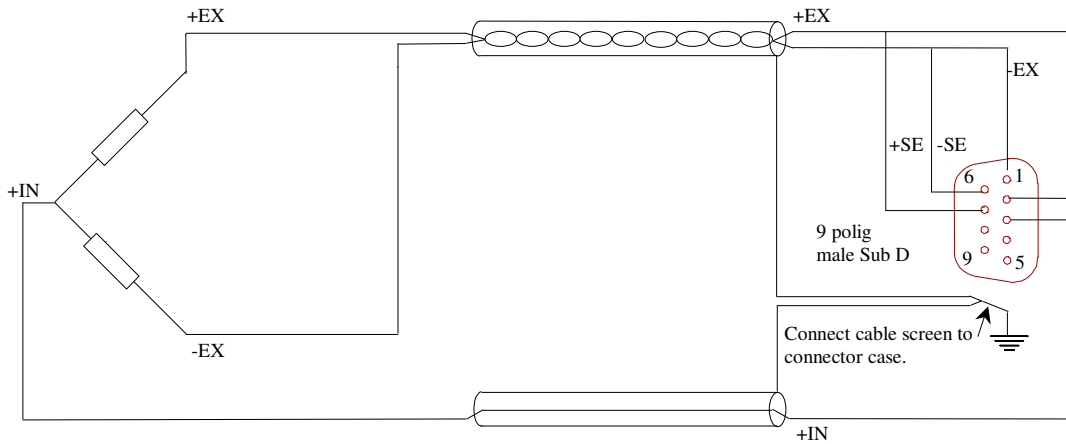

**Figure 3:** Half bridge, 3-wire, straingauge-connection

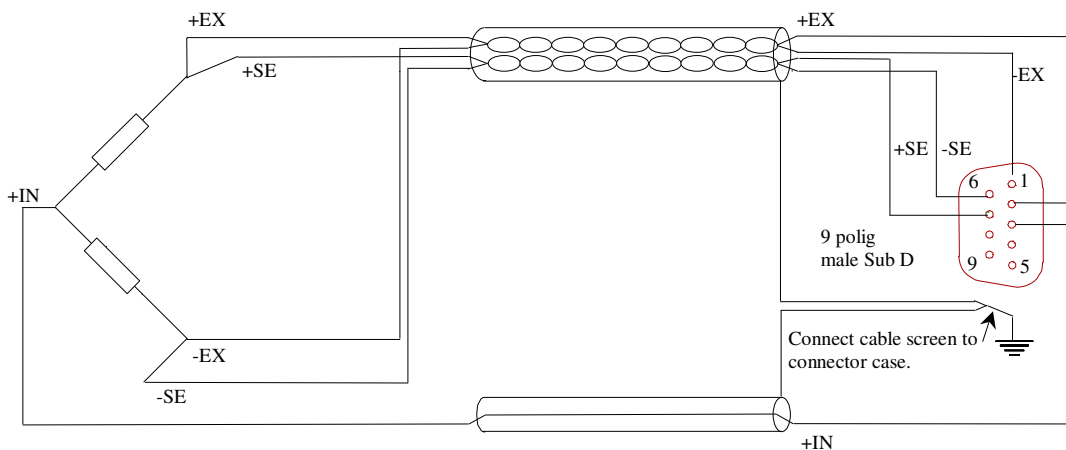
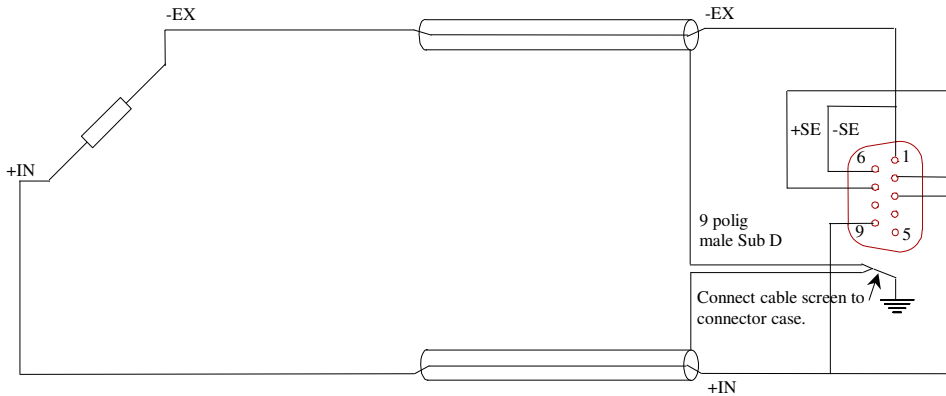

**Figure 4:** Half bridge, 5-wire, straingauge-connection

The connection of the 1/2-bridge completion to -IN sets the amplifier for positive gain: so connecting the +IN signal to +EX gives a positive outputsignal (although in overload). Half-bridge connections are more critical than full-bridge. The leadwire-resistances in the ±EX-lines are in series with the 2 straingauges, in the Wheatstone bridge. Any slight unbalance in these leadwire-resistances will give rise to signal-offset. Every 1mΩ difference in resistance on a 120Ω bridge gives 2 μV/V offset. This may be compensated by use of the internal balance circuit. However, temperature-influence can not be compensated. Short, thick cabling is highly recommended

### 2.1.6 Quarter-bridge using 2-wires

Application of quarter-bridges is the simplest but least accurate way of measuring. The leadwires in 2-wire configurations are completely incorporated in one arm of the strain-gauge-bridge. Every 1 mΩ of cabling-resistance in series with a 120Ω strain-gauge, will directly add 2 μV/V signal-offset, though in practical situations it is more likely to meet several ohm's of resistance



**Figure 5:** Quarter-bridge, 2-wire, strain-gauge-connection

The internal balance-compensation range is 65 mV/V at 5 volt excitation. This allows for 1.25Ω total leadwire-resistance in series with a 120Ω strain-gauge. A bridge-voltage of 0.5 volt however gives a 10 times balance-range and enables 12.5Ω leadwire in series with a 120Ω strain-gauge.

The temperature-influence on the cable-resistance cannot be compensated. The temperature-coefficient of copper of 0.4%/°C will give rise to 8.3 μV/V offset-change for each Ω in series with a 120Ω strain-gauge. Short and thick cabling is evidently necessary!

### 2.1.7 Quarter-bridge using 3-wires

Most of the problems, mentioned before, can be avoided by using the 3-wire connection method. It adds the resistance of the -EX-leadwire to the external strain-gauge, and it adds the resistance of the wire leading to the internal 1/4-bridge completion to this internal 1/4-bridge resistance. Only the difference in leadwire-resistance (and connector contact-resistance) gives signal-offset.

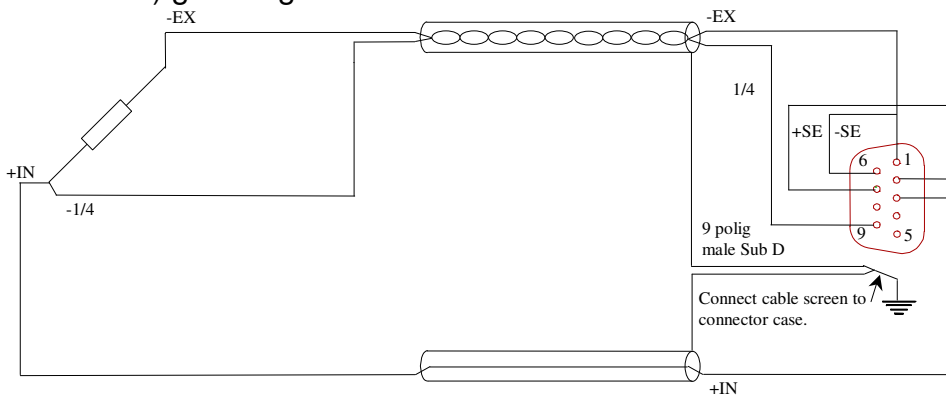

**Figure 6:** Quarter-bridge, 3-wire, strain-gauge-connection.

A similar situation as with the 1/2-bridge connection method has appeared. Every 1 mΩ of difference in resistance, when using 120Ω straingauges, gives a change in signal-offset of 2 μV/V. This may be compensated internally by the balance circuit. However, the temperature-influence cannot be compensated for. Short and thick cabling is again highly recommended.

### 2.1.8 Displacement Transducers

LVDT's, or *Linear-Variable-Differential Transformers* may be configured as full- or half-bridges. The connection method for both possibilities is shown in the next figures.

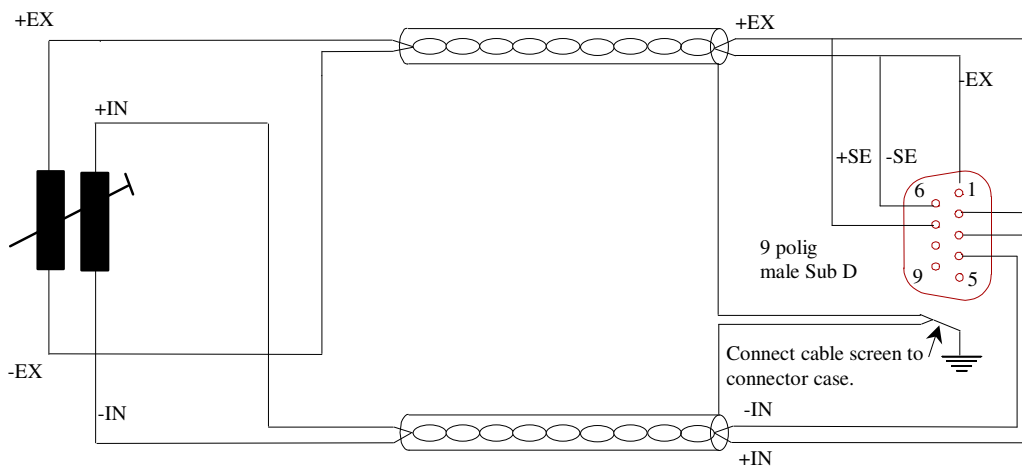

Figure 7: Connection of a full-bridge lvdt.

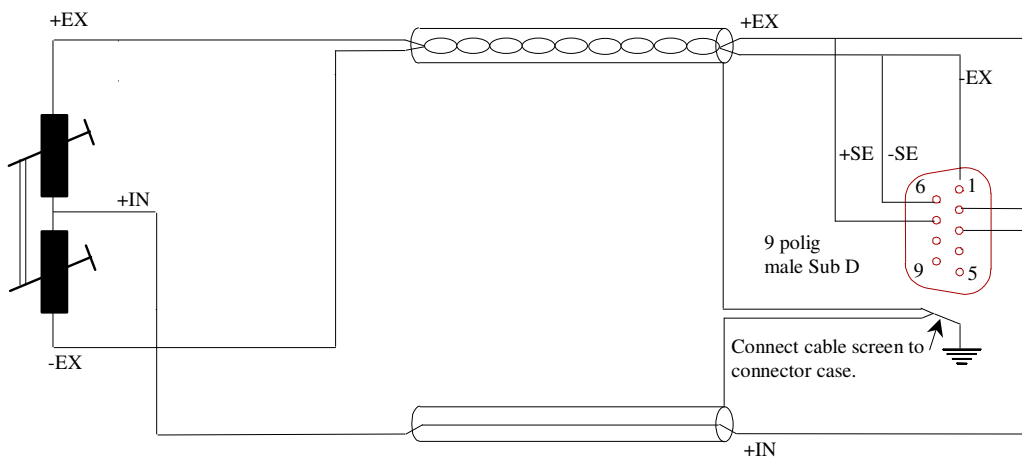
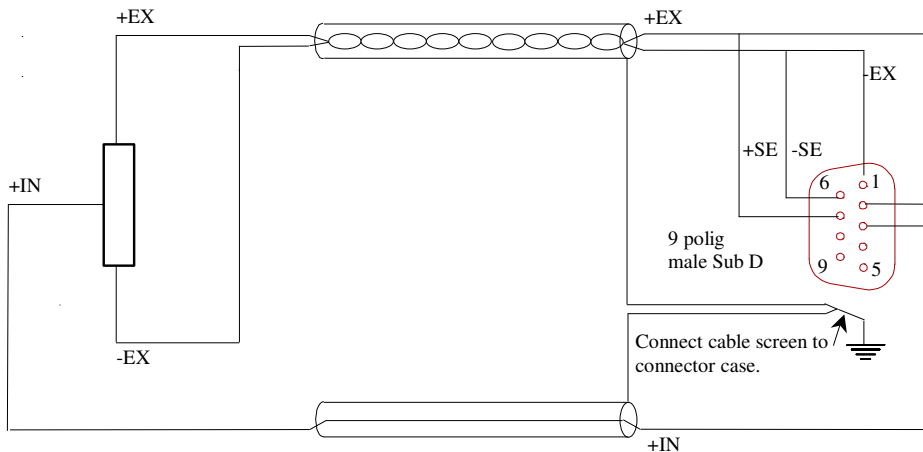

Figure 8: Connection of a half-bridge lvdt

### 2.1.9 Potentiometer connection

A potentiometer can be connected as a half bridge, 3 wire connection:



**Figure 9:** Potentiometer connection as a half bridge, 3-Wire

The linearity of the measurement is influenced by the impedance of the potentiometer. When the potentiometer value is between 120 and 350 Ohm, the linearity of the measurement is within 0.1 %.

When measuring a Potentiometer based sensor, the mid position of the potentiometer will be the zero point. Moving the potentiometer to the minimum or maximum position, the output value will be in the range of –full range to +full range.(-100% to +100%).

Based on the actual input resistance of the CA2CF of about 50K, the following non-linearity will be present when measuring a potentiometer with a higher value:

potentiometer value	linearity
500 ohm	0.15 %
1000 ohm	0.3 %
5000 ohm	1.45 %

## 2.2 Analog inputs on CA4AI

The analog DC-inputs are located on the CA4AI card, which can be ordered as a alternative for a CA2CF card which has 2 carrier frequency channels.

At the back side of PICAS for each CA4AI card 4 detachable screw terminals with each 6 terminals are present, on which the signals/sensors can be connected.

Also each CA4AI cards holds another detachable screw terminals with 2 terminals. On this terminals an 24VDC/80mA power supply is present which can be used as a power supply for electronic sensors.

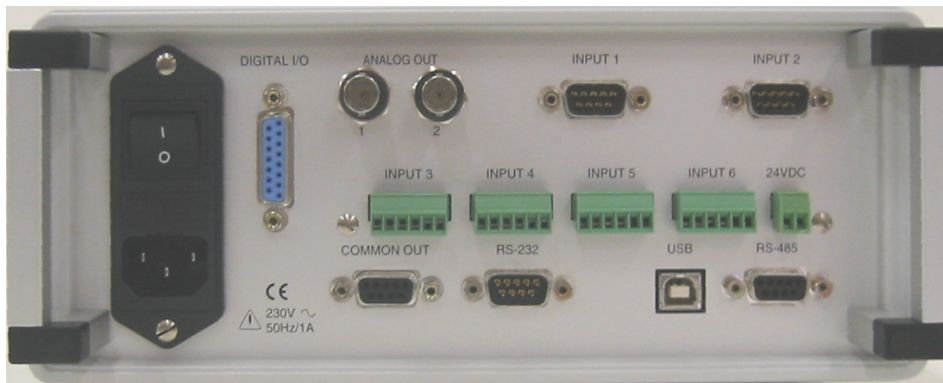

**Figure 10:** Backside of PICAS with 1 CA2CF-card and 1 CA4AI-card.

### 2.2.1 Analog input connector pinout

The following signals are present on the input connector:

- pin 1 : + Supply voltage or current
- pin 2 : - supply current
- pin 3 : +  $I_N$  (+ Input)
- pin 4 : -  $I_N$  (- Input)
- pin 5 : - Supply voltage (0V)
- pin 6 : Screen Ground

(Pin 1 is on the left side of each terminal, when one is looking at the rear site of PICAS.)

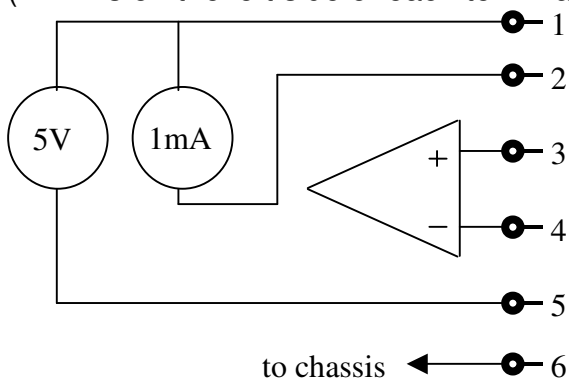
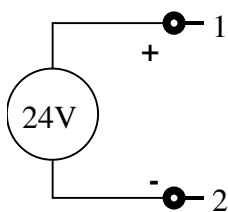

**Figure 11:** Interne connection of the analog input

Connection pinout of the Power-terminal:

- pin 1 : + 24VDC
- pin 2 : - 24VDC

(Pin 1 is on the left side of each terminal, when one is looking at the rear site of PICAS.)



**Figure 12:** Interne connection of the 24VDC supply

This power supply can deliver 80 mA maximum, and is galvanic isolated from PICAS.

### 2.2.2 Potentiometer connection

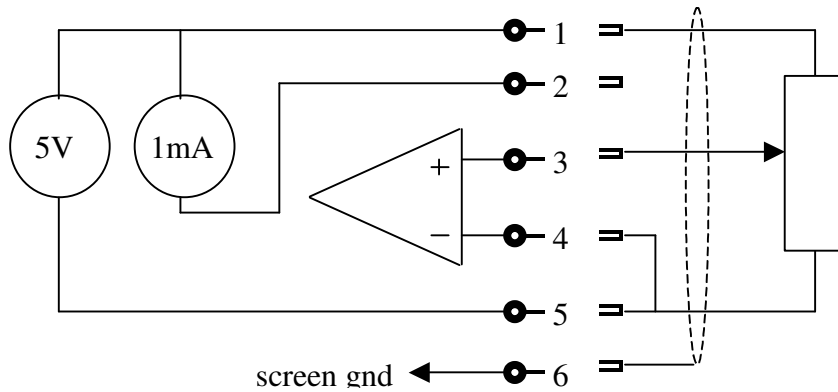

Figure 13: Potentiometer connection

### 2.2.3 Connection of a resistor sensor like a PT100

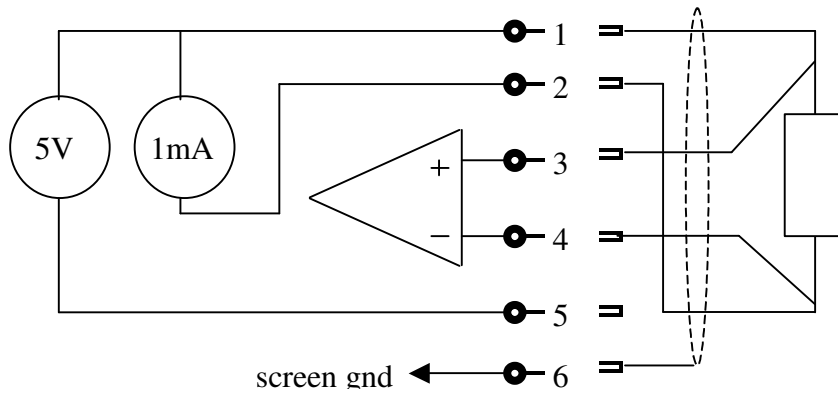

Figure 14: Resistor connection

This connection diagram is used with a PT100 sensor.

### 2.2.4 Connection of a voltage signal

A voltage signal is directly connected to the signal input terminals of the channel.

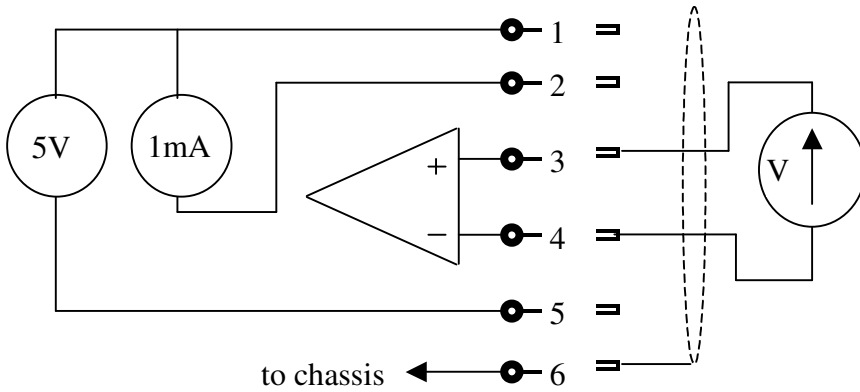

Figure 17: Voltage signal connection

### 2.2.5 Connection of a 4 – 20 mA Sensor

Normally these sensors will deliver a 4 mA signal, when the measured signal is at minimal level. This 4 mA signal is also used as a power supply for the sensor. In this case a 2 wire connection to the sensor is used. The 24VDC supply can be used for these sensors.

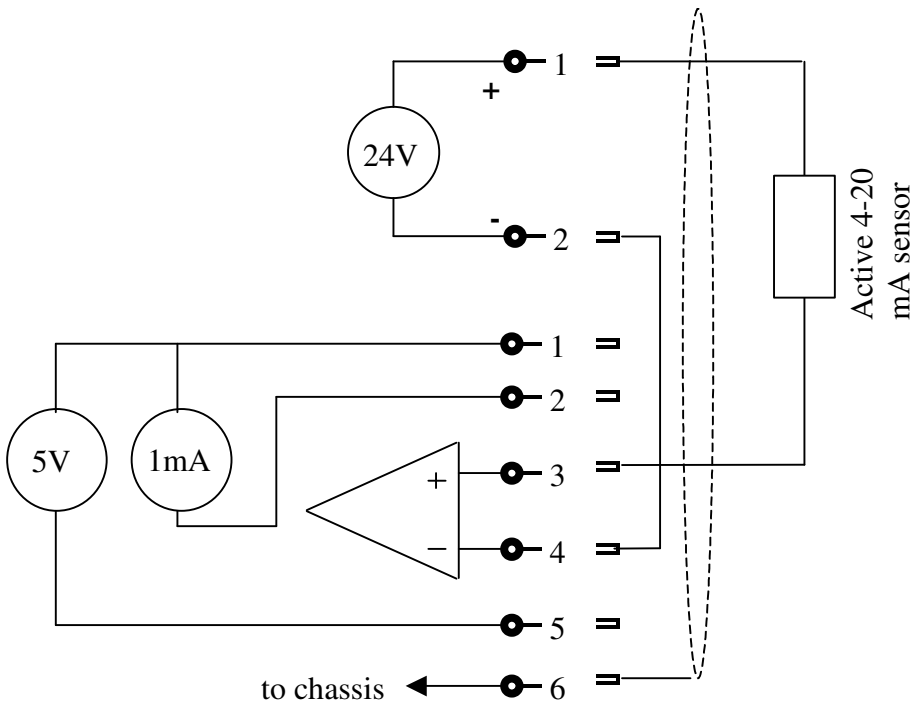

Figure 15: 4 – 20 mA Sensor connection

note: make sure that the sensor can handle the 24VDC supply.

### 2.2.6 Connection of a 0-20mA Sensor

Connection of a current sensor (0-20 mA or 4 – 20mA) when the sensor power supply from PICAS is not used.

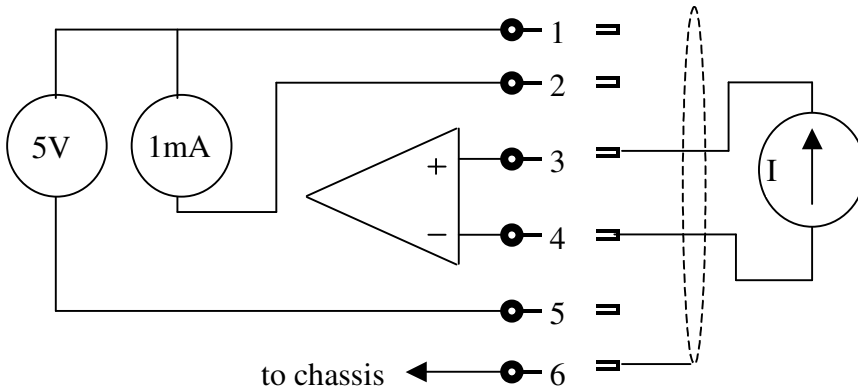

Figure 16: 0 – 20 mA Sensor connection

### 2.2.7 Connection of a Thermocouple element

A thermocouple element is connected like a voltage signal. For the compensation of the cold junction at the screw terminals, the first channel of the CA4AI card is used. With this channel the temperature of the junction must be measured, with a PT100 element.

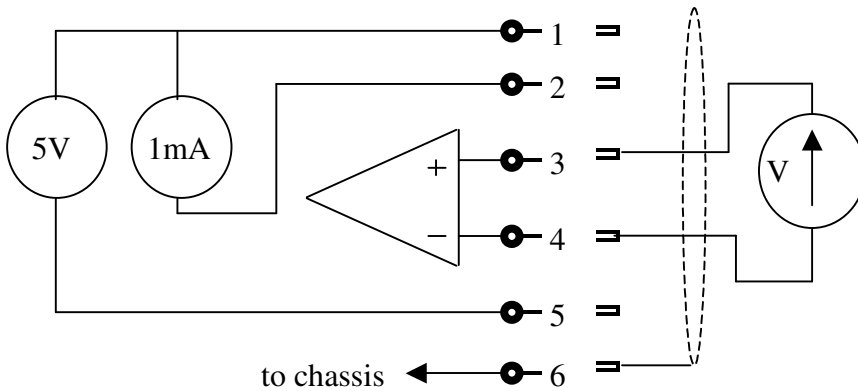
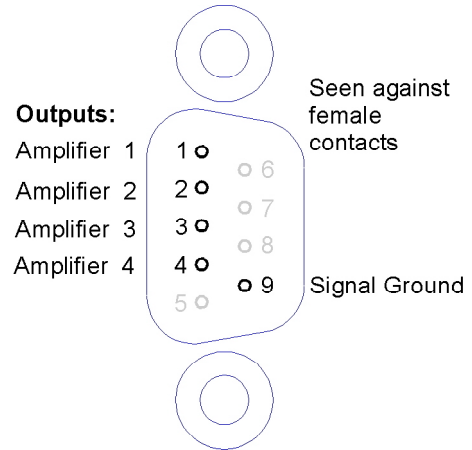

Figure 17: Thermocouple connection

## 2.3 Outputs

### 2.3.1 Combined analog output

- pin 1 : Amplifier output 1
- pin 2 : Amplifier output 2
- pin 3 : Amplifier output 3
- pin 4 : Amplifier output 4
- pin 5 : Screen gnd
- pin 6 : Ground
- pin 7 : Ground
- pin 8 : Ground
- pin 9 : Ground



Through these connections, all 4 outputs (0...+/-10 V) are continuously available. They might be used for connecting an external multiplexer, or other device.

Cable screen should be connected to the connector case. Do not connect to pin 5!

#### Individual analog outputs:

For each Carrier frequency channel, the same output voltage (0... +/-10 V) is also available on a BNC connectors at the rear of the cabinet.

**Note:** The Channels from the CA4AI card do not have an analog output. Not on the board itself and not on this combined analog output connector!!

### 2.3.2 Digital Outputs

Connection diagram for channel 1. The other channels are identical, just use other pins:

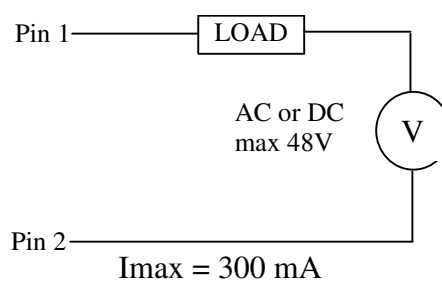

are

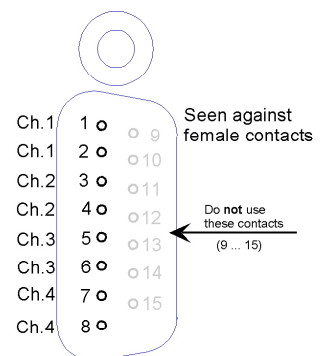

### 2.3.3 Digital Inputs

On the same connector 2 digital inputs are present. These inputs are connected through optocouplers to the processor.

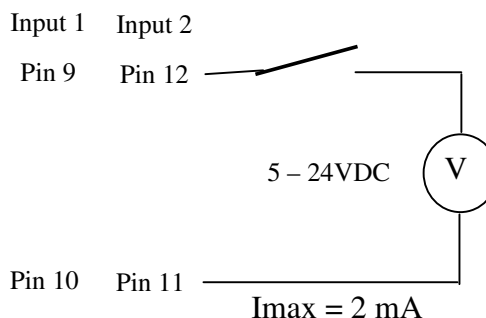

## 2.4 Communication ports

### 2.4.1 RS232 interface

This port can be used to connect a COM-port of a PC. The Baudrate can be selected with System Menu 02.

pin 1	:	-
pin 2	:	RXD
pin 3	:	TXD
pin 4	:	-
pin 5	:	Ground
pin 6	:	-
pin 7	:	-
pin 8	:	-
pin 9	:	-

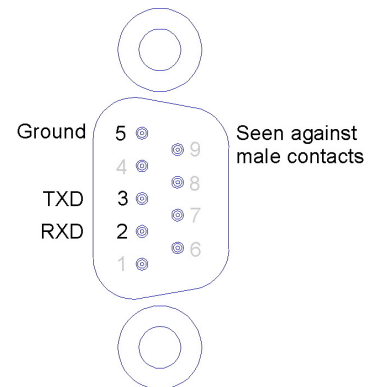

### 2.4.2 USB

This interface is only present on the fast controller. It is used for data communication between the PICAS and the PC.

The PICAS is a USB device, and the USB connector on the back side is a type B connector. It is a USB V1.1 interface.

When the PICAS has a USB interface, only 1 RS485 connector is present.

### 2.4.3 RS485 interface

The RS-485 interface connector is used to build a network (bus) between 2 or more PICAS units. By using System menu 02, this communication can be established. Connections shall be made on a 1-to-1 basis with twisted-pair lines. The SYNC connection is to synchronize the oscillator frequencies of the various units. The cable used for this connection, must have separated shielded twisted pairs for the communication lines and the sync lines, to avoid interference between the communication and synchronization signals. If not used, sometimes the measuring might be disturbed.

- pin 1 : do not use this connection
- pin 2 : Ground
- pin 3 : DATA -
- pin 4 : SYNC -
- pin 5 : Signal Ground
- pin 6 : -
- pin 7 : -
- pin 8 : DATA +
- pin 9 : SYNC +

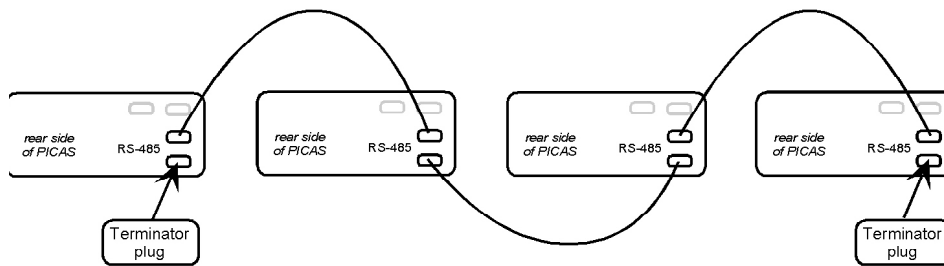
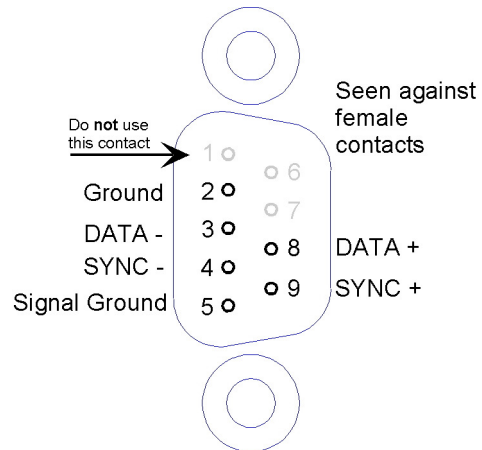

Schematic view of a 4-PICAS network with terminator plugs.

Cable screen should be connected to the connector case. Do not connect to pin 5!

**Note:** on the PICAS with the fast controller only 1 RS485 connector is present. A separate external adapter can be ordered which holds 2 RS485 connectors.

### 2.4.4 Rear panel connections



**Rear panel of a PICAS with 4 Carrier frequency channels**

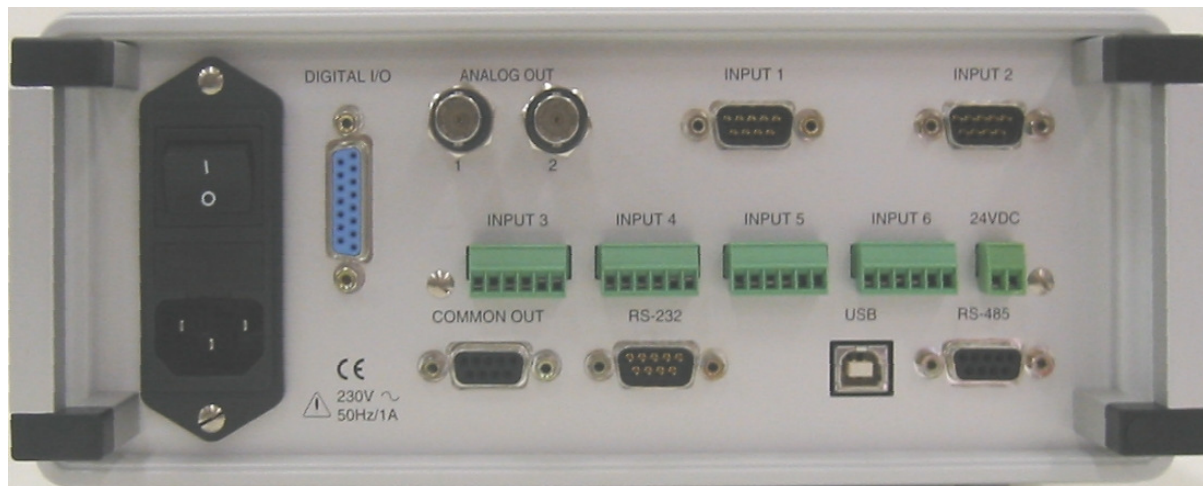

**Rear panel of a PICAS with 2 Carrier frequency channels, 4 analog DC-channels and a USB interface.**

## 2.4.5 Option Sum & difference values

A extra hardware option is available for a 2 channel PICAS.

This option will determine the sum and difference of the values of channel 1 and 2.

The sum value will be available on the analog output of channel 3, and the difference value will be available on the analog output of channel 4.

These sum and difference values are also presented on the display.( see 3.4.3)

## 3 Setting-up the instrument

### 3.1 General

#### 3.1.1 Power up

When the power switch at the rear of the instrument is switched ON („I”), for a short time, the display shows the PEEKEL Instruments logo, after which it comes into the operational mode for Channel 1, Menu 1.

The instrument has to be switched on for at least 15 minutes, before the instrument will operate within the specified accuracy.

#### 3.1.2 Presentation of numbers

Throughout the channel-settings, floating-point numbers are used. They are internally stored as 4 bytes and can take very small and very large values. They are generally shown in the format +1.2345 or +12.345 or +123.45 where the plus sign might be replaced by the minus sign. As an example, values smaller than 1.0000 will be shown as +123.45 m, where *m* stands for milli or 1/1000.

Remember also that +123.45mV (for example) is the same as +0.12345V.

The *m* can be understood as a prefix to the physical unit (*V* in this case) but can also be thought of as a suffix to the value (+123.45 in this case).

PICAS always presents its floating-point numbers using the suffixes *p*, *n*,  $\mu$ , *m*, none, *k*, *M*, *G* and *T*, standing for: *pico*, *nano*, *micro*, *milli*, none, *kilo*, *Mega*, *Giga* and *Tera*.

A value of +825.0  $\mu$ V/V is (for example) the same as +0.825 mV/V. On the other side, values larger than 999.99 will be shown for example as 1.2345 k where *k* stands for kilo or 1000.

**Note** that there are 2 keys on the frontpanel **EXP**→ and ←**EXP** that easily toggle the discussed suffix while editing a number.

#### 3.1.3 Conventions

In this manual, the following conventions are being used:

Any line in a menu shall firstly be selected by putting the cursor in front of it, using the UP / DOWN buttons. After this, the following controls may be used:

*adjustable* means that a value can be entered and edited by using the keyboard. To start editing push ENTER. To leave this mode, push ENTER again.

*selectable* means that a choice can be made from a pre-defined list of expressions etc. which can be scrolled by using the LEFT / RIGHT buttons

*adjustable and selectable* means that, after adjusting the numerical value, the suffix can be selected with the UP / DOWN buttons.

<execute> means that a command can be given by pressing the ENTER button, after which the required command is then being executed.

### 3.1.4 Settings Protection

When the device is completely configured, the settings can be stored in nonvolatile memory. When the same settings are needed again at a later time, they can simple be loaded from this memory. In total 4 of these memory locations are available.

In order to prevent that the settings are accidentally overwritten, it is possible to setup a password protection in the instrument. This will disable the storage of the settings in the nonvolatile memory. All the settings are free to be changed, just the storage is prohibit.

When the instrument is delivered, the password is set to 00000. With this password the protection is off.

There are 3 modes in which the instrument can be regarding to the password protection, these are:

1. Protection is active  
In the "memory menu" an extra line is displayed, to enter the password. On top of this menu at the selection of the actions the "Store setup" command is not available  
The "Password menu" is also not available
2. The user is logged on  
To do this, the right password must be entered on the bottom line of the "Memory menu". After this, the selection of the "Store setup" is available again. Also the "password menu" can be selected, by pushing 3 times on "Menu +".
3. The protection is switched off  
In this case the password is set at "0". This is also the default condition of the instrument. The "Password menu" is available and the extra line at the "Memory menu" is not displayed, because there is no need to log in.

How to enter a new password is explained at the description of the password menu.

## 3.2 Software Installation

### 3.2.1 Loading new versions of firmware (Updates)

New firmware versions are distributed on CD or e-mail.

If new firmware versions becomes available, this can be easily installed into the firmware memory of your PICAS system.

After connecting the communications-port of the PICAS with a COM-port of your PC, just run the UPDATE program from the update diskette

## 3.3 Human Interfacing

### 3.3.1 Navigating the LCD display and the pushbuttons

The functioning of each individual pushbutton on the frontpanel of PICAS will now be explained.

DEVICE + : scrolls through the various Picas devices if connected at the RS-485 bus.

The 4 CURSOR-keys are for navigating through the display (UP-DOWN-RIGHT-LEFT)

CHANNEL + : scrolls through the 4 channels of the Picas device selected.

ENTER : to acknowledge an edited command or to initiate an action if <ENTER> is required.

MENU + : scrolls through the menu selected (either SYSTEM- or CHANNEL-)

SPACE : to type a space when editing.

CANCEL : to cancel a manually edited command

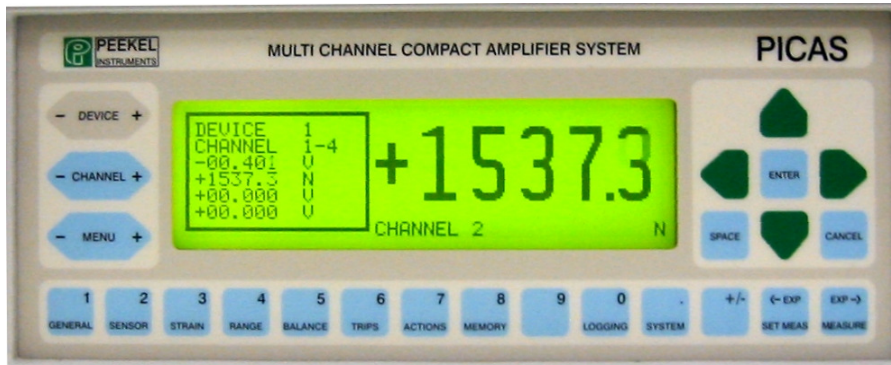

The example above shows the MEASURE display with one channel large (in engineering units) and all 4 output-signals small in volts.

- GENERAL (1) :Shortcut to Channel-menu: GENERAL; (decimal "1" when entering data)
- SENSOR (2) :Shortcut to Channel-menu: SENSOR; (decimal "2" when entering data)
- STRAIN (3) :Shortcut to Channel-menu: STRAIN; (decimal "3" when entering data)
- RANGE (4) :Shortcut to Channel-menu: RANGE; (decimal "4" when entering data)
- BALANCE (5) :Shortcut to Channel-menu: BALANCE; (decimal "5" when entering data)
- TRIPS (6) :Shortcut to Channel-menu: TRIPS; (decimal "6" when entering data)
- ACTIONS (7) :Shortcut to System-menu: ACTIONS; (decimal "7" when entering data)
- MEMORY (8) :Shortcut to System-menu: MEMORY; (decimal "8" when entering data)
- 9 :decimal 9 when entering data
- Logging (0) :Shortcut to System menu: Logging, (decimal 0 when entering data)
- SYSTEM (.) :Shortcut to System-menu: GENERAL; (decimal dot (.) when entering data)
- + / - :plus or minus when entering data
- SET MEAS (<-EXP) :Shortcut to System-menu: MEAS.PARMS; (scroll downward through exponents or engineering unit-suffixes when entering data)
- MEASURE (EXP->) :Shortcut to measuring display (large figures); (scroll upward through exponents or engineering unit-suffixes when entering data)

## General

At the LCD screen, three different groups of displays can be shown:

SYSTEM menu's  
CHANNEL menus  
MEASURE display.

With the SYSTEM menus, the various settings of a DEVICE can be set. With the CHANNEL menu's, the behavior of each of the CHANNELS of a DEVICE can be set. The MEASURE display is generally used when actually measuring. It shows 1 selected channel in large figures and all other channel-outputs of a DEVICE selected in small figures.

For the SYSTEM- and CHANNEL-menu's, the LCD screen is divided in 3 columns. At the left are the various menu names, device- and channel number as selected by the pushbuttons. In the middle are the specific functions, which belong to the menu, chosen and at the right are the individual settings (fields). Some fields can be chosen or set by the user, some cannot be changed and are dictated by the system.

The upper-left portion of the display shows the device as chosen by the *-DEVICE+* pushbutton. With only one device in use (one PICAS instrument), this will always show "1". If more PICAS instruments are connected to the RS-485 bus, these other DEVICES can be selected and displayed.

The next line shows the selected channel.

Each one of the 4 channels is selected with the *-CHANNEL+* button.

The third line (the first in the next box) shows the active **menu-**, followed by the **name** of that menu in the next line.

The menu of your choice is selected with the *-MENU+* button. This will bring you through all settings for the selected channel.

A quicker method is to use one of the short-cut keys 1...6 of the lower row of 14 pushbuttons. These will bring you directly to a specific channel-menu. The names of these menus are also printed on these keys.

The keys *ACTIONS*, *MEMORY*, *SYSTEM* and set *SET MEAS* will bring you directly to one of the system-menu.

Use the up/down-keys to go to the required line, indicated by a black cursor in front of the name of that field in the middle column.

### 3.3.2 Fields

The column at the right of the LCD-display (largest area) shows the **fields** with the parameters (settings) of the currently selected menu.

**Selectable** fields, which represent a **pre-defined choice** (like LANGUAGE in the GENERAL system-menu) can be modified with the left/right keys.

Fields which represent **actions** (like CALIBRATION in the GENERAL channel menu) can be activated by pushing the *ENTER* key. (Such a field shows <execute> and switches temporarily to <wait> during when the action is being executed.

Adjustable fields require **manually introduced numbers** (like BRIDGE-VOLT in the GENERAL channel menu) and can be set by pressing the *ENTER* key. This will move the

cursor to the right and makes it a small edit- (underline-) character. Then the numbered keys, the decimal dot, the +/- key and/or the exponent-keys can be used to type the required value.

The <-*EXP* and *EXP*-> -keys switch the value-suffix or the physical unit suffix between *p*, *n*,  $\mu$ , *m*, none, *k*, *M*, *G* and *T* for micro, milli, none, kilo, mega, giga en tera.

Use *ENTER* to accept this edited value or *CANCEL* to restore the previous value.

Notice that, when channel-information is shown, at the bottom-left of the screen a **measurement** of the amplifier-output voltage is shown.

This enables directly viewing the **effect of the settings** on the amplifier-status.

### 3.4 Measuring Display

To display the measurement values, PICAS has 4 display layouts:

- Actual** the actual value of the selected channel will be presented on the PICAS display in a large font.
- Peak values** the low and high peak values of each channel will be presented on the display.
- Sum & Diff** the sum and difference value of channel 1&2 and channel 3&4 will be presented on the display
- Bar graph** for each channel a 'bar graph' is presented on the display. The actual value is presented as a level in the bar graph. The actual values are also presented in numbers, if there is room on the display.

When more then 4 channels are present in the PICAS, scrolling through the list of channel values can be done with the arrow up / down keys.

Pressing the **measure** button, the selected view will be presented on the display. Pressing this button again, will select the next display layout.

#### 3.4.1 Actual value display

When the **measure** button is pressed, the following display will be presented:



Pressing the **enter** button, will change the unit of the presentation of the values in **Signal V/V**, which presents the value of the input signal, **Output V**, which presents the output voltage of the amplifier and **Physic. Unit**, which present the physical unit of the measured signal. This selection can also be made in the presentation line on System menu 5.

When a measured value reaches the level of trip setting in channel menu, this trip status will be presented on the display as follows:

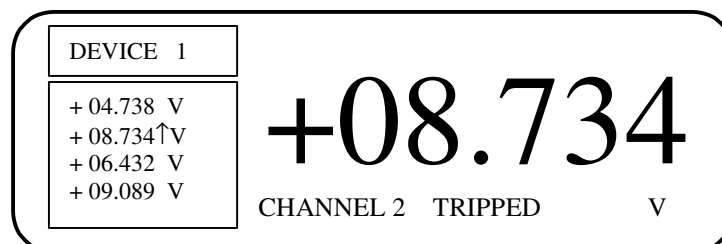

When this display is presented, and the **measure** button is pressed again, the **peak value** display will be presented.

### 3.4.2 Peak value display

The peak value display has the following layout:

DEVICE 1	Peak values	
	Low Peak	High Peak
+ 04.738 V	+01.789	+05.645
+ 08.734 V	-03.342	+09.786
+ 06.432 V	+04.536	+07.687
+ 09.089 V	+03.879	+09.123
	Reset	Runn

At the right side of the display the low and high peak values of each channel are displayed. Those values are updated whenever the peak values changes. On the bottom of the display 2 commands are present. As shown above, none of these commands are selected. With the left and right cursor keys a command can be selected. A selected command is displayed between brackets, like **<Reset>**. The selected command can be given with the **enter** Button.

When no command is selected, the **enter** button has the same functionality as by the actual values display.

When the **<Runn>** is displayed, it means that the peak holding function is running. Pressing the **enter** button when the **<runn>** command is selected, will stop the peak holding option. The last peak values remain on the display, but will not be updated anymore. The **<Runn>** text will be changed in **<Hold>**.

When the peak holding option is running, this function will be activated all the time, even when the peak holding display is not on the screen.

The Hold/Runn and Reset commands can also be given in Set Meas.menu.

When a channel or system menu is displayed, and the measure button is pressed, the setting in Set Meas. menu will determine, whether the actual value or the peak value display is shown.

When the **<Reset>** command is given, the low peak values will be set at “++.”, and the high peak values will be set at “--.”.

If the Peak option is not running, and the reset command is given, the following display will be presented:

DEVICE 1	Peak values	
	Low Peak	High Peak
+ 04.738 V	+++ .+++	--- .---
+ 08.734 V	+++ .+++	--- .---
+ 06.432 V	+++ .+++	--- .---
+ 09.089 V	+++ .+++	--- .---
	<Reset>	Hold

When the peak holding option is on, every 10 milli seconds, 1 channel is measured. This value is used for the peak holding determination. In this way every channel is converted every 40 milli seconds.

When this display is presented, and the **measure** button is pressed again, the **Sum-diff value** display will be presented.

### 3.4.3 Sum – difference value display

This display has the following layout:

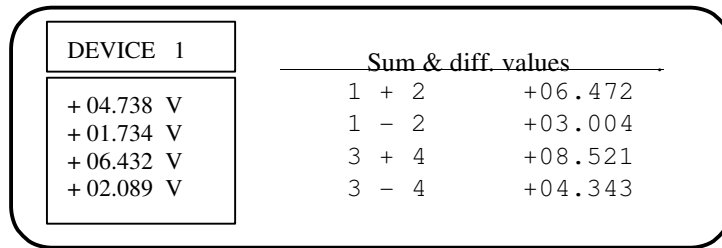

On the right side the sum and difference values of channel 1 & 2 and channel 3 & 4 are displayed. In case of a 2 channel PICAS the values related to channel 3 & 4 are not displayed.

When this display is presented, and the **measure** button is pressed again, the **Bar graph value** display will be presented.

### 3.4.4 Bar graph value display

This display has the following layout:

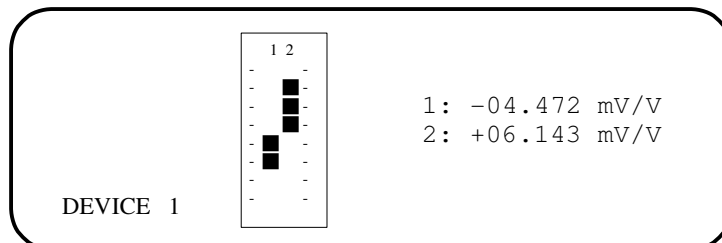

The actual value of the channels is presented on the left in a bar graph view. On the right the actual values are presented as numbers.

When this display is presented, and the **measure** button is pressed again, the **Actual value** display will be presented.

### 3.5 System-menu's

#### SYSTEM menu structure (Overview)

The device (or PICAS unit) with which the keyboard/display is communicating

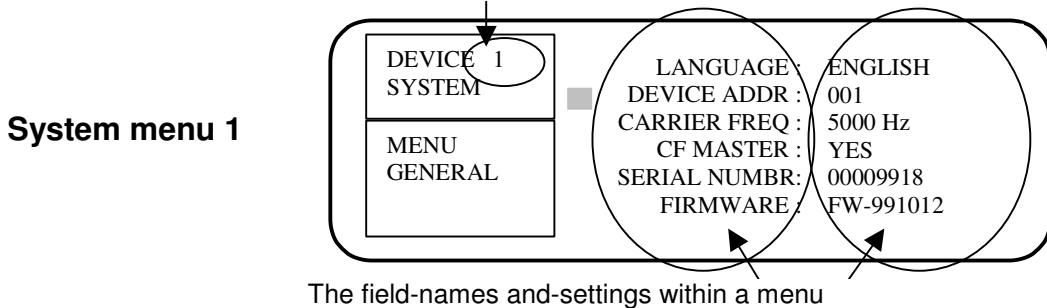

The field-names and-settings within a menu

The cursor indicates the selected field of the menu

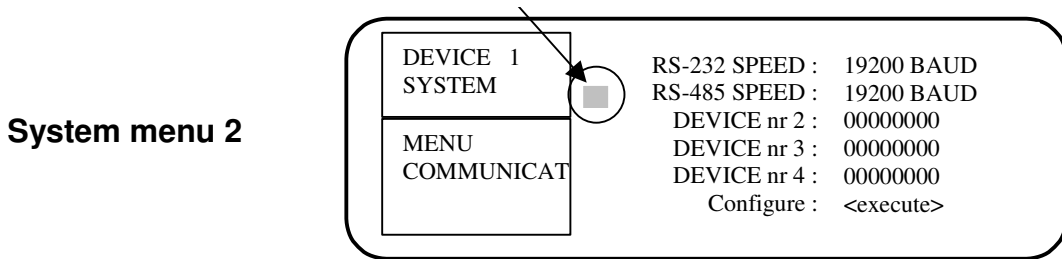

The menu type selected (either CHANNEL or SYSTEM)

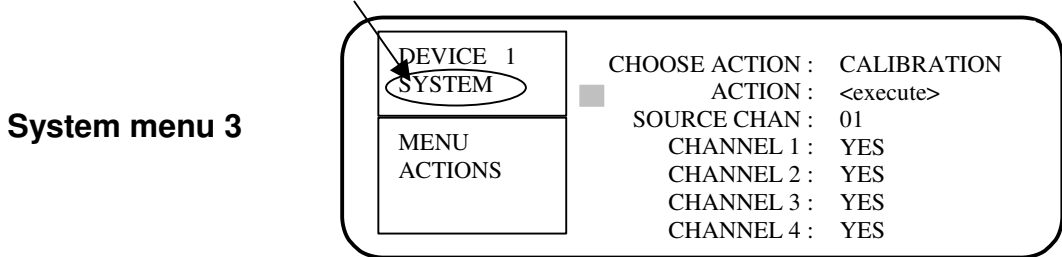

The menu number and its name

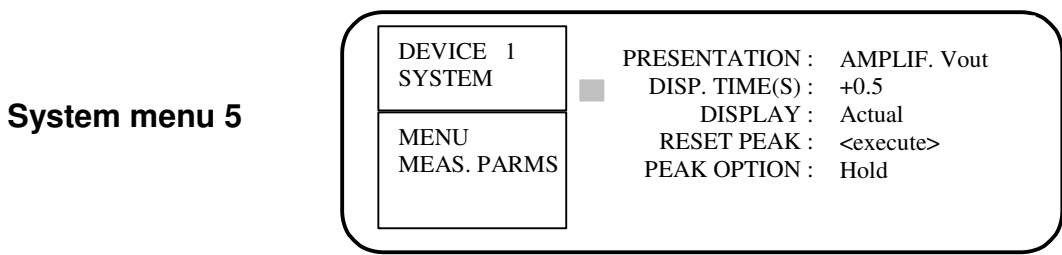
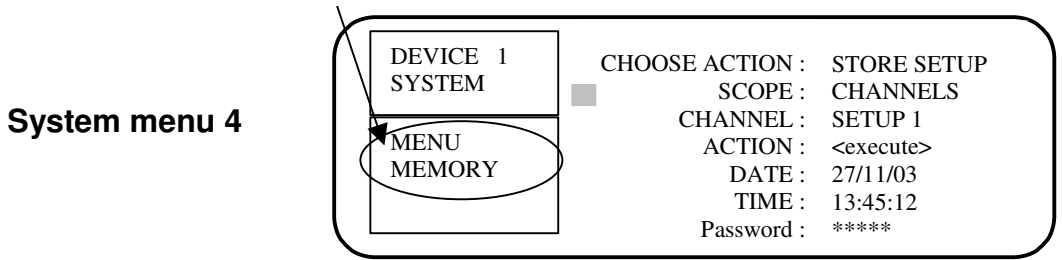

**System menu:**

DEVICE 1 SYSTEM	■	DATALOGGING : INACTIVE
MENU DATALOG 0.0%		CLEAR BUFFER : <execute> FACTOR : 10 msec. CHANNEL 1 : 002 CHANNEL 2 : 002 CHANNEL 3 : 000 CHANNEL 4 : 000

**Password menu:**

DEVICE 1 SYSTEM	■	Password : ****
MENU Password		Set password : <execute> Log off : <execute>

### 3.5.1 System-menu: GENERAL

This menu is for the most general system settings.

DEVICE 1 SYSTEM	LANGUAGE : ENGLISH
	DEVICE ADDR : 001
	CARRIER FREQ : 5000 Hz
MENU GENERAL	CF MASTER : YES
	SERIAL NUMBR: 00009918
	FIRMWARE : FW-991012
	CONTRAST[%] : 57

#### Controls and Functions

Language	<i>selectable</i>	(English / Deutsch / Nederlands)
Device Address	<i>selectable</i>	(1 . . .>>>. . . 99)
Carrier frequency	<i>provided by system</i>	
CF Master	<i>selectable</i>	(Yes / No)
Serial number	<i>provided by system</i>	
Firmware (version no.)	<i>provided by system</i>	
Contrast	<i>selectable</i>	

#### Functional Description

**Language:** can be toggled here between **English**, **German (Deutsch)** and **Dutch (Nederlands)**. If you want to start-up always with the same language, you must specifically save the system-settings from within the system -menu 3: “memory”.

**Device Address:** can be selected from 1 to 99 and is to be used when more than one PICAS are connected to the bus.

**Carrier frequency:** this is automatically displayed and cannot be altered

**CF-master:** should always be set to **yes** if the device is operated separately. If more than one PICAS is connected to the bus, only one is to be called the “master” and the other(s), being “slaves”, should be set to **no**

When more PICAS systems are connected to each other through the RS485 bus, all the PICAS systems should be master, or just 1 PICAS is master and all the other systems are slave. If more then 1 PICAS is “master”, the synchronization frequency on the RS485 will be the sum of the frequencies send by each PICAS. This signal will be out of specification to be used for synchronizing the PICAS units. In this case the slave PICAS will not operate within specifications.

**Serial number:** this is automatically displayed and cannot be altered

**Firmware (version no.):** this is the automatically displayed version-number of the firmware installed and cannot be altered

**Contrast:** this is the contrast setting of the display. A higher number will darken the display.

### 3.5.2 System-menu: Communication

With this menu you can set-up the various parameters for communication between 2 or more PICAS instruments via the RS-485 port and/or using a PC, which is connected via the RS-232 connection.

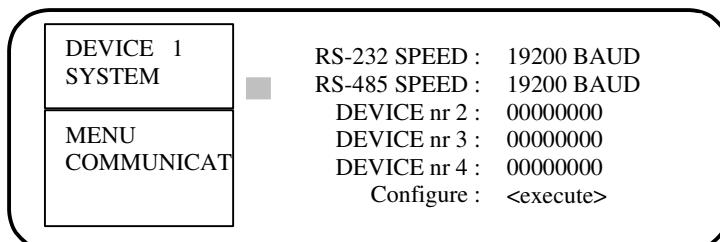

#### Controls and Functions

RS-232 Speed	<i>selectable</i>	(4800,9600, 19200, 38400)
RS-485 Speed	<i>selectable</i>	(9600, 19200, 38400)
Device nr 2	<i>editable</i>	(00000000...99999999)
Device nr 3	<i>editable</i>	(00000000...99999999)
Device nr 4	<i>editable</i>	(00000000...99999999)
Configure	<i>&lt;execute&gt;</i>	

#### Functional Description

In the first and second line you can select the Baudrate with which to communicate with the external device(s). (It shall be noticed that the other device(s) are set to the same Baudrate).

The device from which you can communicate with the other(s) **is always device number 1. Device 1 thus is the Master on the RS-485 bus.**

For Devices numbered 2, 3, 4, the serial numbers can be entered. Serial numbers can be found at the labelsticker but are also fixed in the firmware and can be read in System Menu 1 "General"

With the cursor at **configure** and pressing ENTER, device number 1 sends a broadcast over the bus, informing the devices with the respective serial numbers that from then on they are named Device 2, 3, and so on.

### 3.5.3 System-menu: Actions

This menu enables the user to order a number of centralized ACTIONS, which then can be performed by the system in one go.

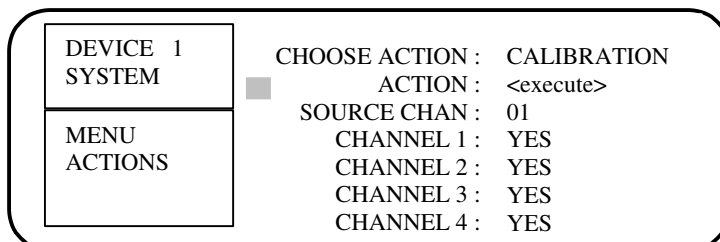

#### Controls and Functions

Choose Action	<i>selectable</i>	(Calibration / Copy Params / Auto-Balance / Disable BAL. / Use Balance)
Action	<i>&lt;execute&gt;</i>	
Source Chan.	<i>selectable</i>	(01...04)
Channel 1	<i>selectable</i>	(Yes / No)
Channel 2	<i>selectable</i>	(Yes / No)
Channel 3	<i>selectable</i>	(Yes / No)
Channel 4	<i>selectable</i>	(Yes / No)

#### Functional Description

In the first line you can select the required action, hence you can have the instrument <execute> that action by selecting the second line and pressing ENTER.

With Source Chan. you can select any one of 4 channels from which to copy parameters Channel 1 ... Channel 4 can be set to YES or NO to instruct if such channel is taking part in the centralized ACTION.

#### ACTION Description

- Calibration** When this command is given, the bridge supply will be calibrated with the use of the sense lines.
- Copy Params** Copies the parameter from the source channel to the selected channel.
- Auto Balance** Performs an auto balance action to all selected channels.
- Disable Bal** Switches OFF the use of the balance function for the selected channels.
- Use Balance** Switches ON the use of the balance function for the selected channels.

### 3.5.4 System-menu: Memory

This menu allows storage of all 4 amplifier-settings and system-settings.

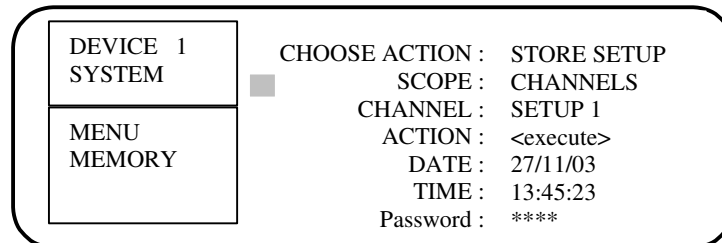

#### Controls and Functions

Choose Action	<i>selectable</i>	(Store Setup / Get Default / Get Setup)
Scope	<i>selectable</i>	(Channels / System / Chan + System)
Channel	<i>selectable</i>	(Setup 1...Setup 4)
Action	<i>&lt;execute&gt;</i>	
Date*	<i>editable</i>	current date day/month/year
Time*	<i>editable</i>	current time: hour:minute:seconds
Password*	<i>editable</i>	always displayed with '*' characters

\* These items are only available on the PICAS with the USB controller

#### Functional Description

With **action** you select if you want to **store setup-**, **load setup-** or **get default-** parameters. The **default** values are factory-set and can always be used as a safe starting point with known values. The action "Store setup" is only available when the instrument is not in the protected mode.

The **scope** allows you to save/recall the settings of the **channels** only, the **system** only or both the **system + channels** at the same time. As the **system**-parameters do not need a change too often, here it is usually sufficient to select **channels**.

4 different **channel** settings can be saved. At start-up, PICAS will always load Setup 1.

If the cursor of this menu points to **memory**, pressing the **ENTER** button saves all current Channel- and System- settings into the instrument's non-volatile memory.

What is saved exactly, is defined by the **action** and **scope** settings (see corresponding paragraphs).

→ Note that you must deliberately save parameters before they can be recalled. Changes in amplifier-settings are **not** automatically stored.

→ Note that PICAS always starts up with loading channel Setup 1. If you do not save your settings deliberately, the saved settings may be those from earlier measurements with totally different settings. Therefore, first check all parameters for your application or load default values.

The Date and Time lines will display the actual date/time when the menu is selected. The values will only be updated when the complete menu is updated. To set the date/time just enter the actual value and the instruments will active this date/time when entered.

On the last line a password can be entered. When the correct password is entered, the selection of the action “Store Setup” will be possible. When the password is set at “0”, this last

### 3.5.5 System-menu: Measuring Parameters

This menu sets the presentation mode of the local display.

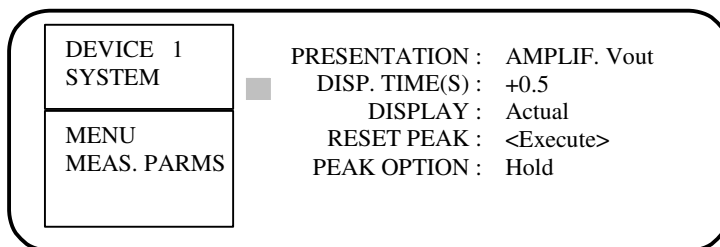

#### Controls and Functions

Presentation	<i>selectable</i>	(Signal V/V / Physic. Unit / Output V)
Disp. Time(s)	<i>adjustable</i>	(+0.1 /... / +5.0)
Display	<i>selectable</i>	(Actual / Peak values / Sum & Diff / Bargraph)
Reset peak	<i>&lt;execute&gt;</i>	
Peak option	<i>selectable</i>	(Hold/Runn)

#### Functional description

The *presentation* parameter defines how measurements are presented on the display . When set to *amplif. Vout* the value represents the output voltage of the amplifier. When set to *amplifier* the value represents the input signal of the amplifier in V/V ( volts-per-volt). When set to ***physic.unit***, the display shows the physical unit, as chosen in Channel Menu 4: Range with the ***range of*** parameter. In that case the presentation can be either with the sensor-unit, the straingauge-unit or again the amplifier-signal in V/V. The value ***disp.time(s)*** indicates the display update time-interval. Depending on the time chosen, the instrument calculates the average value of the number of actually measured values in that time. This average time is only used when the channel value is displayed in a large font, and by the calculation of the trip values.

The setting of ***Display*** will influence the presentation.

- Actual*** the actual value of the selected channel will be presented on the PICAS display in a large font.
- Peak values*** the low and high peak values of each channel will be presented on the display.
- Sum & Diff*** the sum and difference value of channel 1&2 and channel 3&4 will be presented on the display
- Bar graph*** for each channel a ‘bar graph’ is presented on the display. The actual value is presented as a level in the bar graph. The actual values are also presented in numbers, if there is room on the display.

When PICAS is in measuring mode, the presentation can be changed with the “enter” key.

### 3.5.6 System-menu: Datalog

This menu is only available on devices where the datalog option is enabled. It allows the user to perform a measurement and store measurement data in the internal memory of the device. The memory will retain the data for 48 hours after switching the device off or unplugging it from its power source. The data can be retrieved from the device at a later time using a PC and the Signasoft 6000 software.

The differences in this function between the PB6000 and PB6100 controller are mentioned in the text.

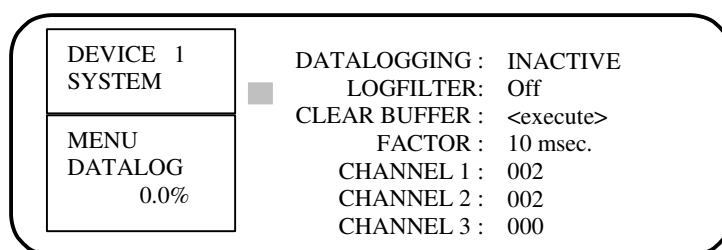

#### Controls and Functions

Datalogging	<i>selectable</i>	(Inactive / Cyclic Log / Log & Fill RAM)
Logfilter	<i>selectable</i>	(Off / Dig.Input 1 / Dig. Input 2 / Trip Ch. 1 / ...)
Clear Buffer	<i>&lt;execute&gt;</i>	
for the PB6000 controller		
Factor	<i>selectable</i>	(10 msec. / 1 sec)
Channel 1	<i>editable</i>	(000 ... 250)
Channel 2	<i>editable</i>	(000 ... 250)
Channel 3	<i>editable</i>	(000 ... 250)
Channel 4	<i>editable</i>	(000 ... 250)
for the PB6100 controller		
Factor	<i>selectable</i>	(100usec / 1 sec
Channel 1	<i>editable</i>	interval time, see text
Channel 2	<i>editable</i>	interval time, see text
Channel 3	<i>editable</i>	interval time, see text
Channel 4	<i>editable</i>	interval time, see text

#### Functional Description

To store a measurement in RAM, the buffer must be empty. The device can not store several different measurements in RAM. Select the clear buffer function and press ENTER to remove previous measurement data. Beware: once the buffer has been cleared, the measurement data can not be recovered.

To configure a measurement, the measurement interval must be configured for all channels. The interval for all channels can be selected in steps.

PB6000: the selectable steps are 10 msec or 1 second.

For each channel, a number can be entered. This number, multiplied by the factor, indicates the measurement interval for the channel. When '000' is entered for a channel, that channel will not be measured.

The maximum number which can be entered is 250.

PB6100: the selectable steps are 100 usec, 1 msec, 10 msec., 100 msec or 1 second.

For each channel an interval time can be entered. This interval time must be a multiply of the selected step. The maximum interval time is 65000 x selected step

To start the measurement, select 'cyclic log' or 'log & fill RAM' on the datalog line. In 'log & fill RAM' mode, the device will measure until the available RAM is full. In 'cyclic log' mode, the device will continue measuring until stopped manually, overwriting old measurement data when the buffer is full. The percentage on the left side of the display shows the current usage of the buffer.

The buffer can contain up to about 29500 for the PB6000 and 500000 for the PB6100 measurement values. Due to bookkeeping overhead, this total amount will be lower when the interval times are higher (ie. for slower measurements).

PB6000: If you attempt to start a new measurement while there is still data in the buffer, the message 'Clear buffer first!' will be displayed and the measurement will not start.

Use the 'clear buffer' function to remove the previous measurement, or transfer it to a PC first.

If the configured measurement speed can not be matched, a message 'Datalog speed too high!' will be displayed and the measurement will not start.

PB6000: The device can perform up to 100 measurements per second.

PB6100: The device can perform up to 10000 measurement per second.

Up to 20000 measurement per second can be achieved when all the channel intervals are the same. This setting can only be done using a PC with the appropriated software.

It is possible to filter the storage of measurement values based on digital inputs or trips.

When the Logfilter option is set to a digital input, logging will only be performed when the input is activated. The display shows 'armed' while logging is active without the input being active (no measurement values are stored), and 'logging' when the input is active.

When the Logfilter option is set to an active trip on a channel, logging will only be performed when the channel is tripped.

### 3.5.7 System-menu: Password

This menu is only available when the PB6100 controller is in use.  
 In this menu a password can be entered, to protect the instrument settings in nonvolatile memory to be overwritten.  
 When the correct password is entered, the command to store the settings is available.  
 When the used has “logged off” the settings can be altered but cannot be stored.

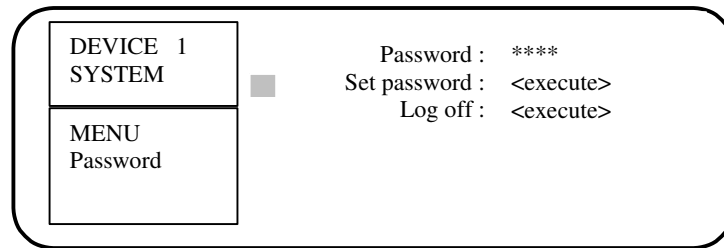

Controls and Functions		
Datalogging	<i>selectable</i>	(Inactive / Cyclic Log / Log & Fill RAM)
Password	<i>editable</i>	a numeric value can be entered here, which is larger then -32000 and smaller then +32000.
Set password	<i>&lt;execute&gt;</i>	When this command is given the entered password is saved and made active
Log off:	<i>&lt;execute&gt;</i>	After this command, the entered password is erased, and the protection is activated

#### Functional Description

This menu is only available when the correct password is entered in the “Memory menu” or if the password protection is not activated. At the first line a password can be entered. Choose a numeric value between -32000 and 32000, enter this value and give the command “Set password”. Now the password is saved in nonvolatile memory. To enter the protected mode, give the command “Log off”. Because this menu is only available in the non-protected mode, this menu will immediately disappear when the “Log off” command is entered.

### 3.6 CA2CF channel menu's

#### CHANNEL menu structure (Overview)

Channel menu 1

DEVICE 1 CHANNEL 1	■	BRIDGE-VOLT : +5.0
MENU GENERAL +0.0577 V		SIGNAL MODE : NORMAL POLARITY : NORMAL CALIBRATION : <execute> BRIDGE LOAD : +120.0 BRIDGE COMPL. : 1/1 BRIDGE PRESENTATION : Default

Channel menu 2

DEVICE 1 CHANNEL 1	■	SENSOR RANGE : +10.0 k
MENU SENSOR +0.0577 V		PHYSIC UNIT : N SENSOR V/V : +1.0 m MEAS. SENSOR : <execute>

Channel menu 3

DEVICE 1 CHANNEL 1	■	K-FACTOR : +2.0
MENU STRAIN +0.0577 V		BRIDGE FACTOR : +4.0 USE E-MODUL : NO E-MODULUS : +200.0 k E-MOD UNIT : N/mm <sup>2</sup>

Channel menu 4

DEVICE 1 CHANNEL 1	■	RANGE OF : Signal V/V
MENU RANGE +0.0577 V		RANGE : +1.0 m UNIT : V/V AMPLIF.Vout : +10.0

Channel menu 5

DEVICE 1 CHANNEL 1	■	AUTO BALANCE : <execute>
MENU BALANCE +0.0577 V		R-BALANCE : +0.0 C-BALANCE : +0.0 UNIT : V/V USE BALANCE : YES

Channel menu 6

DEVICE 1 CHANNEL 1	■	TRIP VALUE : 890 k
MENU TRIPS +0.0577 V		HYSTERESIS : 2 k UNIT : kN TRIP CONTROL : HIGH SIGNAL ACT. PERIOD : 200 ms

### 3.6.1 CA2CF -menu: GENERAL

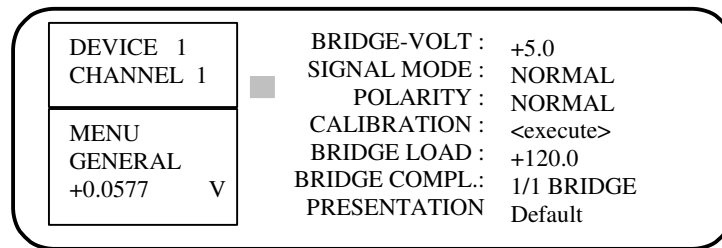

#### Controls and Functions

Bridge-Volt	<i>adjustable</i>	(0.5 ...5 volts)
Signal Mode	<i>selectable</i>	(Normal / Capacitive)
Polarity	<i>selectable</i>	(Normal / Inverted)
Calibration	<i>&lt;execute&gt;</i>	
Bridge Load	<i>adjustable</i>	(60.0 >>> 3000 Ω)
Bridge compl.	<i>Selectable</i>	(1/1, 1/2, 1/4 120Ω or 1/4 350Ω)
Presentation	<i>selectable</i>	(default / Output V / Signal V/V / Physical unit)

#### Functional Description

The first line *bridge-volt* defines the excitation-voltage of the transducer or straingauges. Values from 0.5 ... 5 volt are possible. There is a 10% margin to compensate cable-losses when using 6-wire connections (sensing). This allows for (e.g.) 12 Ω total cable-resistance when using 120 Ω straingauges at 5 volt excitation.

After the value is accepted for *bridge-volt*, the amplifier will automatically perform a calibration. It measures the real bridge-voltage using the sense-lines and corrects any deviation. It is therefore necessary that the sense-lines are connected on the bridge-connector. *When sensing is not used to compensate cable-losses, it is still necessary to connect the sense-lines on the connector itself.*

This calibration can also be done later with the **calibration**-parameter. It is even necessary when another sensor or straingauge with different resistance is connected to the amplifier. Just press the **ENTER**-button at this line, while the sensor and sense-lines are connected. → *Notice that the output voltage of the amplifier will be disturbed during the calibration. Null and full-scale reference-measurements are done and will be visible in the amplifier output signal.*

*The local display will not show any error, because it just does not measure during the calibration.*

The **polarity** parameter gives an easy method of changing the polarity of the output voltage without changing the wiring. But use *normal* if you do not need inverted polarity.

*Inverted polarity* is the same as a negative gain. When such a negative gain is entered, the polarity will be on inverted mode.

The **signal-mode** is usually set to *normal*. In **capacitive** mode, the amplifier does not measure the normal resistive signal from the straingauges but the capacitive, phase-shifted signal, caused by cable-capacitance and other parasitic causes. Although the amplifier is designed to distinguish between the desired measurement and error-signals, when this signal is large (full-scale or more) it can affect the accuracy of the normal measurement. Capacitive unbalance is mostly observed in quarter-bridge configurations with several meters of cabling.

At the **Bridge load** line, the bridge load seen from the input of the amplifier must be entered. This value is used, together with the input impedance from the amplifier (about 50K $\Omega$ ), to optimize the measurement value. When a bridge with a large impedance is used, this value becomes more important, because the voltage division at the input will cause an error in the measurement.

At the **Bridge compl.** line, the internal bridge complementation can be selected. A selection can be made from the following options:

- 1/1 bridge: with this selection a full bridge must be connected
- 1/2 bridge: with this selection the internal 1/2 bridge is connected to the –IN pin. The external 1/2 bridge must be connected to the +IN pin
- 1/4 → 120 $\Omega$  with this selection a 120  $\Omega$  resistor is internally connected between the 1/4 pin and the +EX pin. Just connect 1 120 $\Omega$  strain gauge between the –EX and the 1/4 pin, to measure this strain gauge.
- 1/4 → 350  $\Omega$  with this selection a 350  $\Omega$  resistor is internally connected between the 1/4 pin and the +EX pin. Just connect 1 350 $\Omega$  strain gauge between the –EX and the 1/4 pin, to measure this strain gauge.

With the **presentation** setting, the presentation of the value on the display is influenced. When it is set to default, the presentation will follow the setting in System menu 5. When it is set to another value, this setting will overrule the setting in the system menu 5.

### 3.6.2 CA2CF -menu: SENSOR

This menu specifies the connected sensor like a load-cell or a LVDT. If plain strain gauges are used, it is easier to use the strain gauge-menu number 3.

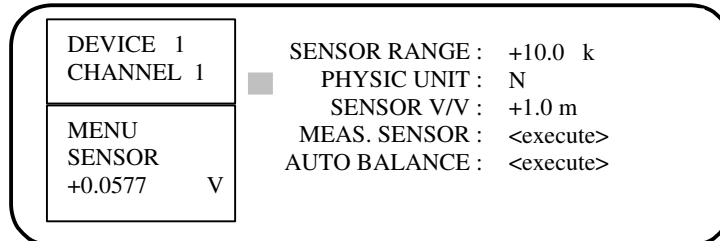

#### Controls and Functions

Sensor-Range	<i>adjustable</i>	(-10,000 . . . >>> . . . +10.000 with
	<i>selectable suffix</i>	(pico /... / Tera)
Physic.Unit	<i>selectable</i>	(N, Nm, N/mm <sup>2</sup> , Pa, ppm, psi, t, V, V/V,%, bar, °C / g, g/mm <sup>2</sup> , G, Hz, inch, K, lbs, m, m/m, m/s or m/s <sup>2</sup> )
Sensor V/V	<i>editable</i>	(00,000 . . . >>> . . . 10.000 with
	<i>selectable suffix</i>	(pico /... / Tera)
Meas. Sensor	<i>&lt;execute&gt;</i>	
Auto-Balance	<i>&lt;execute&gt;</i>	

#### Functional Description

**Sensor-range** specifies the physical stimulus (force, displacement) that will generate **sensor v/v** at the amplifier-input. In the shown example a load-cell is specified that gives 1 mV/V signal if a force of 10000 Newton is applied. These values can often be read from the datasheet and represent mostly full-load signals. But the values in the sensor-menu can also be obtained from in-house calibration and they do not necessarily have to be full-load signals. If you have measured and know that your 10kN load-cell produces 0.83mV/V if 8.3kN is applied, those values would do the job as well.

The parameter **physic.unit** specifies the physical unit of the sensor. A load-cell could have *t* or *N* as unit and an lvdt could have *m* (meter, as in centimeter, millimeter) as unit.

The sensor-calibration can automatically be done with this menu.

First the sensor must be placed in a zero position condition. Now the **Auto Balance** command must be give. After this the measured value will be at **zero**.

AT this time the sensor must be placed in a known position. situation, for example at a load-cell 8.3kN is applied. Now the **meas.sensor** command is given. The input signal level is measured and the sensor sensitivity is calculated and presented on the display at the line **sensor v/v**.

### 3.6.3 CA2CF -menu: STRAIN

This menu is specifically intended for using with experimental strain gauge-measurements. If you measure a complete sensor, like a load-cell or an LVDT, it is easier to use the sensor-menu number 2

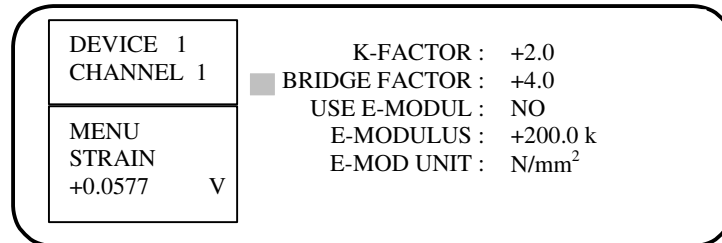

#### Controls and Functions

K-Factor	<i>adjustable</i>	
Bridge-Fact.	<i>adjustable</i>	
Use E-Modul	<i>selectable</i>	(No / Yes)
E-Modulus	<i>adjustable</i>	( - 1.0000.....+ 10 000 )
	<i>and selectable</i>	(pico...>>>... Tera)
E-Mod unit	<i>fixed</i>	(N/mm <sup>2</sup> )

#### Functional Description

The **k-factor** can be copied from the datasheet of the manufacturer of the strain gauges. The **bridge-factor** is basically equal to the number of active strain gauges in the bridge. If applicable it can also be used for the correction of Poisson effects in strain gauges configurations.

When using half- and quarter ridge configurations be sure to connect the internal bridge-completion resistors through the bridge-connector. These built-in bridge-completion resistors are: 120 Ω for 1/4 bridge-completion and 2 x 240 Ω for 1/2 bridge-completion (see page 5).

The above parameters allow calculation of the signal into the strain unit *m/m*. If further calculations are to be done to obtain the stress in the material, the **e-modulus** parameters may be set. Set the **use e-modul** line to *yes* and set the e-modulus-unit and -value as appropriate for the material to be tested.

### 3.6.4 CA2CF -menu: RANGE

By this menu the amplifier can be set to a certain measurement-range.

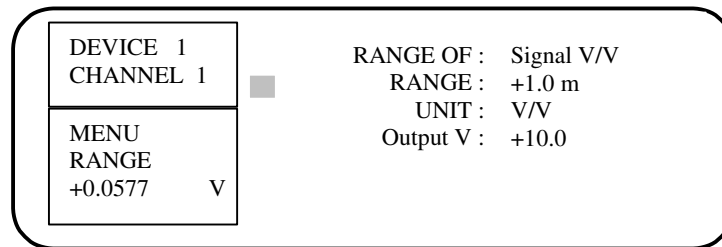

#### Controls and Functions

Range of	<i>selectable</i>	(Signal V/V / Sensor / Strain)
Range	<i>adjustable</i>	(-10.0 .... +10.0)
	<i>and selectable</i>	(pico- /... / Tera-)
Unit	<i>provided by system</i>	
Output V	Maximum voltage on output when input voltage is equal to the range	

#### Functional Description

The parameter **range of** determines the interpretation of the **range**-parameter. As it is set to *amplifier* the range represents the amplifier-range in V/V. When it is set to *sensor*, the range takes into account the values from the sensor-menu and the range is shown with the physical unit from the sensor-menu. If *range of* is set to *strain*, the *range* is calculated using the values in the strain-menu and the physical unit will be m/m, g/mm<sup>2</sup> or N/mm<sup>2</sup>. As the *range of* parameter is changed, the **unit** parameter will change as well. That *unit* can not be modified from within this menu but only in the sensor- and strain gauge-menu's.

The *range of* parameter also determines how measurements are shown on the display, when the *presentation* parameter in the system menu 5 (behind the *set meas* button) is set to *physic. unit*.

The electrical range of the amplifier (when *range of* is set to *amplifier*) can be set between 100uV/V and 1 V/V. Using smaller bridge-voltages than 5 volt, this has limitations on the smallest value that can be set as the range.

If the **range** is adjusted wrongly, an indication:

**Calc. gain too large !!**  
**Settings adjusted !!**

appears in the lower part of the LCD-display. The settings are adjusted to the highest possible gain.

The value for **Output V** determines the output-voltage when full-scale input signals are applied. It is thereby possible to match to data-acquisition equipment, connected to the amplifier-output.

Most modern systems accept the -10...+10 volt signals that PICAS delivers by default.

→ **Note that the full-scale output voltage, as specified with *Output V*, is not the same as the maximum output voltage. Even when 5 volt full-scale is chosen, a maximum of 14 volt may arise on the output during overload-conditions.**

### 3.6.5 CA2CF -menu: BALANCE

This menu gives the offset-adjustment of the sensor or strain gauges.

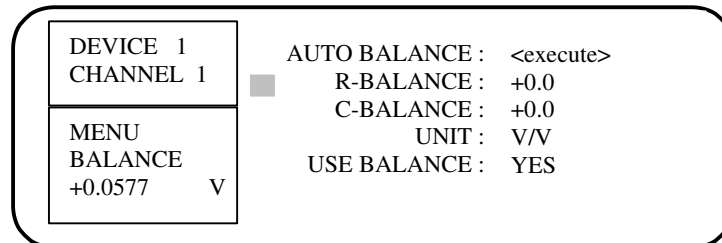

#### Controls and Functions

Auto-Balance	<execute>	
R-Balance	provided by system or adjustable	(-100.0 ... + 100.0)
	and selectable	(pico- /... / milli-)
C-Balance	provided by system or adjustable	(-10.0 ... + 10.0)
	and selectable	(pico- /... / milli-)
Unit	provided by system	
Use Balance	selectable	(Yes / No)

#### Functional Description

If a sensor or strain gauge-bridge is connected with known unbalance, that unbalance-value can be entered as **...-balance**. That value is then electronically subtracted from the input signal in the amplifier.

The use of the input balance can temporarily be disabled by setting **use balance** to *no*. The value does not change and can be used again by setting *use balance* to *yes* again.

When a sensor or strain gauge-bridge with unknown unbalance is connected, it is possible to use the **auto-balance**-function. If enter is pressed on the appropriate line, a measurement is done and the result is placed on the *..-balance* lines. The output of the amplifier should be near 0 volt. In the larger ranges, an output signal of a few millivolts may be left.

In the 100uV/V range however a maximum of 50mV may be left at the output because of the 0.5uV/V resolution of the input balance.

The balance values are displayed and entered in the unit, displayed in this menu. The unit value cannot be changed in this menu.

### 3.6.6 CA2CF -menu: TRIPS

This menu offers the possibility to monitor the measured value and add “trip” -functions to each measurement.

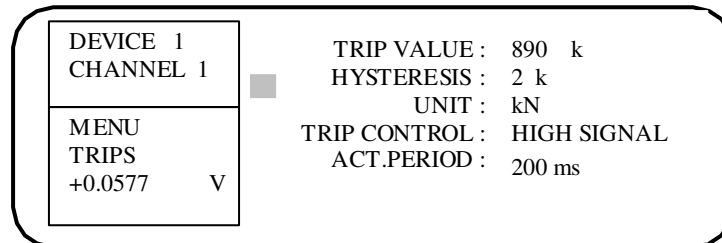

#### Controls and Functions

Trip-Value	<i>editable</i>	(0000000...999999)
Hysteresis	<i>editable</i>	(0000000...999999)
Unit	<i>provided by system</i>	
Trip-Control	<i>selectable</i>	(unactive / high signal / low signal)

#### Functional Description

Of each PICAS, each one of 4 channels can be selected in this menu by CHANNEL (up or down).

Before setting the trip-levels, all other parameters have to be set. Adjusting Trip-Levels is practically the last adjustment before actual measuring starts.

The **trip-value** can be set to a numerical value at which a switching action of the tripping function has to work. This value shall be any level from within the measuring range (see **range menu**).

**Hysteresis** can be set as the value at which the trip function goes back to normal again. Normally this is a percentage of the **trip-value**.

(Example: you wish to get a trip at 98% of the maximum measured value, of, say “100”. You then set the Trip-Value at “98”. If you now adjust the hysteresis at “3”, the trip mechanism will perform a switch action at the digital output (for connections see 3.5.3). This digital output will switch back to normal when the measured value reaches a value of “98 - 3 = 95”. The digital output switches again if the measured value then comes to 98 again.)

Unit is automatically displayed, according to the measuring range set earlier.

Trip-Control offers the facility of either not tripping at all, tripping when a high level, or tripping when a low level of the measured value is reached.

Act.Period (Activation Period) determines the minimum time span during which a trip will remain active. When set to anything other than 0, the trip will stay active for at least the given amount of time. If after this time the trip is still active, another span of the same duration is entered.

### 3.7 CA4AI channel menu's

**Menu General:**

Device	1	■	Excitation :	5V
Channel	3		Meas. Type :	Voltage
MENU			Presentation :	Default
General				
+00.006	V			

**Menu Sensor**

Device	1	■	Physic. unit :	N
Channel	3		Sensor max. :	+100.0
Menu			Sensor min. :	+0.0
Sensor			Signal max. :	+10.0
+00.006	V		Signal min. :	+0.0

**Menu Range**

Device	1	■	Range of :	Meas. value
Channel	3		Range :	10 V
Menu			Unit :	V
Range				
+00.006	V			

**Menu Tara**

Device	1	■	Auto Tare :	<execute>
Channel	3		Tare :	+0.0
Menu			Unit :	V
Tare			Use Tare:	Yes
+00.006	V			

**Menu Trips**

Device	1	■	Trip value :	0.0
Channel	3		Hysteresis :	0.0
Menu			Unit :	N
Trips			Trip control :	Inactive
+00.006	V		Act. Period :	0

### 3.7.1 CA4AI menu: GENERAL

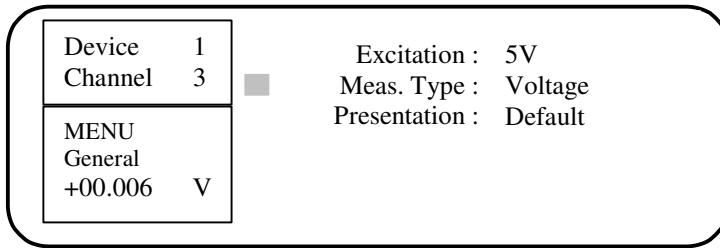

#### Controls and Functions

	<i>selectable</i>	5 V or 1 mA
Excitation		
Meas. Type:	<i>selectable</i>	Voltage: 20mV – 10V
		Current: 5mA – 50 mA
		Resistor: 100 - 7500Ω
		PT100
		PT1000
		CJC (Only selectable on channel 1)
		On channel 2,3 and 4 of each card the following thermocouples can be selected:
		Type B,E,J,K,N,R,S and T
Presentation	<i>selectable</i>	(default / Signal V/V / Physical unit)

#### Functional Description

In this menu the general settings for the channel are made. At first a choice must be made for the sensor excitation to be Voltage of Current.

The next selection is the type of measurement to be done. In this menu only the type is selected. The range selection is made in the Range menu.

#### Thermocouple measurement.

This is a special case measurement, because 2 temperatures has to be measured. First of course the signal on the terminals of the CA4AI card. Somewhere in the connection of the thermocouple a junction is present. The temperature of this point must be known to determine the correct temperature measured by the thermocouple. This extra measurement must be done with channel 1. The selected type must be CJC, and a PT100 must be connected to the input of channel 1. This PT100 must be placed near the junction of the thermocouple connection.

A special item is available to measure the temperature of the terminal of channel 1.

Due to this, no more then 3 thermocouple signal can be measured on each CA4AI card.

### 3.7.2 CA4AI menu: Sensor

Device	1	■	Physic. unit :	N
Channel	3		Sensor max. :	+100.0
Menu			Sensor min. :	+0.0
Sensor			Signal max. :	+10.0
+00.006	V		Signal min. :	+0.0

#### Controls and Functions

Physic.Unit	<i>selectable</i>	(N, Nm, N/mm <sup>2</sup> , Pa, ppm, psi, t, V, V/V, %, bar, °C / g, g/mm <sup>2</sup> , G, Hz, inch, K, lbs, m, m/m, m/s or m/s <sup>2</sup> )
Sensor-max	<i>adjustable</i>	(-10,000 . . . >>> . . . +10.000 with
	<i>selectable suffix</i>	(pico /... / Tera)
Sensor-min	<i>adjustable</i>	(-10,000 . . . >>> . . . +10.000 with
	<i>selectable suffix</i>	(pico /... / Tera)
Signal-max	<i>adjustable</i>	(-10,000 . . . >>> . . . +10.000 with
	<i>selectable suffix</i>	(pico /... / Tera)
Signal-min	<i>adjustable</i>	(-10,000 . . . >>> . . . +10.000 with
	<i>selectable suffix</i>	(pico /... / Tera)

#### Functional Description

When the range information of a sensor is known, this information can be entered in this menu. At the fields **Sensor max** and **Sensor min** the physical limits of the sensor are entered. At the field **Signal max** and **Signal min** the electrical signal values belonging to the mentioned physical limits are entered.

PICAS will now calculate the correct physical value from each measured signal value.

### 3.7.3 CA4AI menu: Range

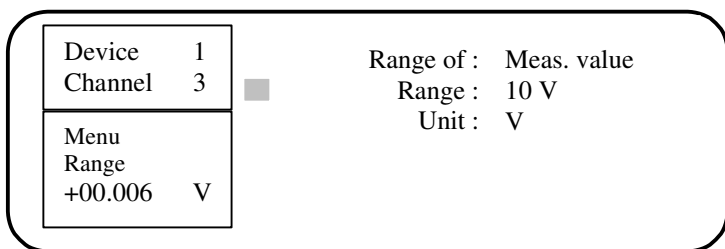

#### Controls and Functions

Range of      *selectable*      (Signal V/V / Sensor)  
 Range        *selectable*      *see table below.*  
 Unit         *provided by system*

#### Functional Description

The selection of **Range of** selection will influence the presentation of the measured value in physical units. When **Sensor** is selected, the displayed value will be in the units entered in the Sensor menu.

The selection of the Range value depends on the type of measurement selected in the **General** menu and are:

Voltage	Current	Resistor
+ - 10V	± 100 mA	4000 Ω
+ - 5V	± 50 mA	2000 Ω
+ - 2V	± 10 mA	500 Ω
+ - 0.5 V	± 5 mA	100 Ω
+ - 0.1 V		
+ - 50 mV		
+ - 20 mV		

Temperature measurement	
PT100	-200 - +590 °C
PT1000	-200 - +590 °C
Type B	+250 - + 1820 °C
Type E	-200 - + 1000 °C
Typ eJ	-200 - + 1200 °C
Type K	-200 - + 1370 °C
Type N	-200 - + 1300 °C
Type R	- 50 - + 1760 °C
Type S	- 50 - + 1760 °C
Type T	- 50 - + 390 °C

### 3.7.4 CA4AI menu: Tara

Device	1	Auto Tare :	<execute>
Channel	3	Tare :	+0.0
Menu		Unit :	V
Tare		Use Tare:	Yes
+00.006	V		

#### Controls and Functions

Auto-Tare	<execute>
Tare	provided by system or adjustable (-100.0 ... + 100.0) and selectable (pico- /... / milli-)
Unit	provided by system
Use Tare	selectable (Yes / No)

#### Functional Description

When a measured signal is at 'zero' level this command can be given. The presented value will be corrected by the value displayed at the "Tare" line. This correction is activated by the "Auto Tare" command. The balance values are displayed and entered in the unit, displayed in this menu. The unit value cannot be changed in this menu.

### 3.7.5 CA4AI menu: Trips

Device	1	Trip value :	0.0
Channel	3	Hysteresis :	0.0
Menu		Unit :	N
Trips		Trip control :	Inactive
+00.006	V	Act.period :	0

#### Controls and Functions

Trip-Value	<i>editable</i>	(0000000...999999)
Hysteresis	<i>editable</i>	(0000000...999999)
Unit	<i>provided by system</i>	
Trip-Control	<i>selectable</i>	(inactive / high signal / low signal)
Act.Time	<i>selectable</i>	(0 / 100 ms / 200 ms / ... / 60 m)

#### Functional Description

Before setting the trip-levels, all other parameters have to be set. Adjusting Trip-Levels is practically the last adjustment before actual measuring starts.

The **trip-value** can be set to a numerical value at which a switching action of the tripping function has to work. This value shall be any level from within the measuring range (see **range menu**).

**Hysteresis** can be set as the value at which the trip function goes back to normal again. Normally this is a percentage of the **trip-value**.

(Example: you wish to get a trip at 98% of the maximum measured value, of, say "100". You then set the Trip-Value at "98". If you now adjust the hysteresis at "3", the trip mechanism will perform a switch action at the digital output (for connections see 3.5.3). This digital output will switch back to normal when the measured value reaches a value of "98 - 3 = 95". The digital output switches again if the measured value then comes to 98 again.)

Unit is automatically displayed, according to the measuring range set earlier.

Trip-Control offers the facility of either not tripping at all, tripping when a high level, or tripping when a low level of the measured value is reached.

Act.Period (Activation Period) determines the minimum time span during which a trip will remain active. When set to anything other than 0, the trip will stay active for at least the given amount of time. If after this time the trip is still active, another span of the same duration is entered.

When a channel is in the Trip status, this is presented on the display:

- on the left side of the display, after the unit of the measured value a "up" or "down" arrow is presented (↑ o. ↓)
- in the Measure-Display on the bottom line the text „TRIPPED“ is displayed.

Only channel 1 to 4 have a digital output on the trip status. When a channel exceeds the trip level the output will be activated.



## 4 Problem resolving

Error description	Possible course
The connected sensor does not generate any signal	Is the sensor supply present? 1. Is the CF-MASTER in the general system menu selected to 'YES' 2. If 2 or more PICAS units are used and the CF are synchronized, only 1 PICAS must have the CF-MASTER to 'YES', At the other units the CF-MASTER must be at 'NO'. Check the cabling of the RS485 connectors.
The measurement signal is changing with a slow sinus wave form.	When more PICAS units are used together, it is possible that the different carrier frequencies will influence each other. In this case the PICAS units must be synchronized (see General system menu)
The linearity of the signal is not within specifications.	When the sensors have a higher impedance, a error may occur at the input. To compensate this, the correct impedance must be entered in the general channel menu.

## 5 Technical Specifications

### Carrier frequency inputs of the CA2CF-card

#### General

Typical accuracy class	0.1%
Bandwidth (-3 dB)	2000 Hz
Maximum cable length:	500m
Sensor connection	2-, 3-, 4-, or 6-wire configurations

#### Bridge supply (transformer-isolated)

Supply voltage	0,5... 5V (adjustable)
Voltage accuracy	$\pm 0.05\%$
Frequency	5 kHz
Frequency accuracy	$\pm 1\%$
Load	60...1000 $\square$ 0,1% 1000... 3000 $\square$ >0,1%
Internal bridge-completion	$\frac{1}{2}$ - bridge und $\frac{1}{4}$ - bridge 120 $\square$ / 350 $\square$

#### Measuring input (transformer-isolated)

Ranges (@5V excitation):	$\pm 100 \mu\text{V/V} \dots \pm 1 \text{ V/V}$
Input Filter: (High pass)	> 500 Hz
Max. Common Mode Voltage	200V
Common Mode Rejection (50 Hz)	>120 dB
Serial Mode Rejection:	>66 dB
Capacitive input overload	max.7x range permissible
Special input filtering for noise reduction	

#### Balance control

R-balance	+/- 65 mV/V
C-Balance at 120 $\Omega$ bridge	up to 10 nF

#### Output

Full scale voltage	+/- 10 V
Protection	long-term short circuit allowed
Maximum capacitive load	10 nF
Maximum cable length	100 m (@100 pF/m)
Frequency (-3 dB)	< 2000 Hz
Filter type	7-pole low pass Butter worth -42 dB/Octave

### Analog inputs of CA4AI-card

#### General

Typical accuracy class	0.1%
Bandwidth (-3dB)	10 Hz
Sensor connections	2-, 3-, or 4-wire configuratieons

#### Sensor supply:

Voltage:	5V $\pm 0.1\%$ (max. 50 mA) (Maximum for 4 channels together is 100 mA)
Current:	1mA $\pm 5\%$ (max. 7,5k $\Omega$ )
Power for active sensors	24VDC (max 80mA) (galvanic separated from inputs)

**Input:**

Measurement range :	Voltage:	$\pm 20 \text{ mV} - \pm 10\text{V}$
	Current:	$\pm 5 \text{ mA} - \pm 100 \text{ mA}$
	Resistor	100 $\Omega$ - 7500 $\Omega$
	Temperature	PT100 -200 - +590 °C
		PT1000 -200 - +590 °C
		Type B +250 - + 1820 °C
		Type E -200 - + 1000 °C
		Type J -200 - + 1200 °C
		Type K -200 - + 1370 °C
		Type N -200 - + 1300 °C
		Type R - 50 - + 1760 °C
		Type S - 50 - + 1760 °C
		Type T - 50 - + 390 °C
		Cold Junction Compensation with a PT100 on channel 1 of the CA4AI-card.
Input filter (-3 dB)		10 Hz
Filter type:		2-pole low pass Butter worth
Input resistance:		10 M $\Omega$
Max. input voltage:		$\pm 35\text{V}$
Max. input current (only is current mode):		120 mA
Common Mode voltage		$\pm 12\text{V}$

The CA4AI board does **not** have an analog output for each input channel!

**Controller Boards**

	PB6000	PB6100
<b>A/D-converter</b>	<b>16 Bit</b>	
Amplifier calibration	per Software and D/A-converter	
Synchronization of carrier frequency	digital (with other PICAS units)	
Interfaces	1x RS232	
	1x RS485	
		1x USB V1.1
Digital outputs (solid state switch)	for trip generation max. 48VAC/DC / 300mA	
Max total conversion speed:	100 Hz	20.000Hz
Measurement value storage	29.000 values	500.000 values

**Housing**

PICAS	250 x 330 x 110 mm (B x T x H)
Power supply	100 - 240 VAC / 50/60 Hz
Operating temperature	0 -..+50 °C

Note: the PB600 controller board is not used in new systems.